

## 75A 650V Trenchstop Insulated Gate Bipolar Transistor

### 1 Description

Using DongHai's proprietary Trench design and advance FS technology, the 650V FS IGBT offers superior and switching performances, high avalanche ruggedness easy parallel operation

### 2 Features

- FS Trench Technology, Positive temperature coefficient
- Low saturation voltage:  $V_{CE(sat)}$ , typ = 1.7V @  $I_C = 75A$  and  $T_j = 25^\circ C$
- Extremely enhanced avalanche capability

### 3 Applications

- Welding
- UPS
- Three-level Inverter

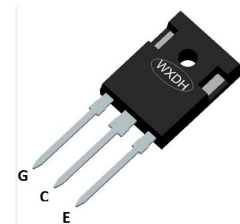
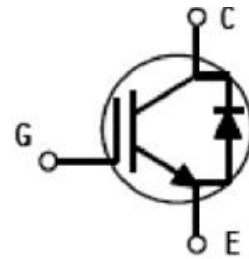

Type	$V_{CE}$	$I_C$	$V_{cesat}, T_j=25^\circ C$	$T_{jmax}$	Package
DGC75F65M	650V	75A	1.7V	175°C	TO-247-3L

### 4 Electrical Characteristics

#### 4.1 Absolute Maximum Ratings ( $T_j=25^\circ C$ , unless otherwise noted)

Parameter	Symbol	Value	Units
Collector-to-Emitter Voltage	$V_{CE}$	650	V
Gate-to-Emitter Voltage	$V_{GE}$	$\pm 30$	V
DC Collector current	$I_C$	$T_C=25^\circ C$	150
		$T_C=100^\circ C$	75
Pulsed Collector Current <sup>(1)</sup>	$I_{CM}$	300	A
Diode forward current	$I_F$	$T_C=25^\circ C$	150
		$T_C=100^\circ C$	75
Diode Pulsed Current	$I_{FM}$	450	A
Short circuit withstand time, $V_{GE}=15V$ , $V_{CC}=400V$ , $T_j=150^\circ C$	$T_{SC}$	10	$\mu s$
Power Dissipation	$P_{tot}$	$T_C=25^\circ C$	440
		$T_C=100^\circ C$	220
Junction Temperature Range	$T_j$	-45~175	$^\circ C$
Storage Temperature Range	$T_{stg}$	-45~150	$^\circ C$
Soldering temperature	$T_L$	260	$^\circ C$

**4.2 Thermal Characteristics**

Parameter	Symbol	Rating	Units
IGBT Thermal Resistance,Junction to Case-sink	$R_{thJC}$	0.34	$^{\circ}C/W$
IGBT Thermal Resistance,Junction to Ambient	$R_{thJA}$	40	$^{\circ}C/W$
Diode Thermal Resistance,Junction to Case-sink	$R_{thJC}$	0.58	$^{\circ}C/W$

**4.3 Electrical Characteristics** ( $T_j=25^{\circ}C$ , unless otherwise noted)

Parameter	Symbol	Test Condition	Value			Units
			Min	Typ	Max	
<b>Off Characteristics</b>						
Collector-to-Emitter Breakdown Voltage	$V_{CES}$	$I_C=1mA, V_{GE}=0V$	650	--	--	V
Collector-to-Emitter Leakage Current	$I_{CES}$	$V_{CE}=650V, V_{GE}=0V, T_j=25^{\circ}C$	--	--	25	$\mu A$
		$V_{CE}=650V, V_{GE}=0V, T_j=175^{\circ}C$	--	--	2000	$\mu A$
Gate-to-Emitter Leakage	$I_{GES}$	$V_{GE}=\pm 30V, V_{CE}=0V$	--	--	$\pm 250$	nA
<b>On Characteristics</b>						
Gate Threshold Voltage	$V_{GE(th)}$	$V_{CE}=V_{GE}, I_C=1mA$	4.5	5.5	7	V
Collector-emitter saturation voltage	$V_{CEsat}$	$V_{GE}=15V, I_C=75A, T_j=25^{\circ}C$	--	1.7	2.4	V
		$V_{GE}=15V, I_C=75A, T_j=175^{\circ}C$	--	2.2	--	V
Transconductance	$g_{fs}$	$V_{CE}=20V, I_C=75A$	--	67	--	S
<b>Dynamic Characteristics</b>						
Input Capacitance	$C_{iss}$	$V_{CE}=25V, V_{GE}=0V, f=1MHz$	--	5474	--	pF
Output Capacitance	$C_{oss}$		--	243	--	
Reverse Transfer Capacitance	$C_{rss}$		--	35	--	
<b>Switching Characteristics</b>						
Turn-on delay time	$t_{d(on)}$	$V_{CE}=400V, I_C=75A, R_g=5\Omega, V_{GE}=15V,$ 感性负载, $T_j=25^{\circ}C$	--	41	--	nS
Rise time	$t_r$		--	125	--	nS
Turn-off delay time	$t_{d(off)}$		--	143	--	nS
Fall time	$t_f$		--	95	--	nS
Turn-on energy	$E_{on}$		--	2.65	--	mJ
Turn-off energy	$E_{off}$		--	1.91	--	mJ
Total switching energy	$E_{ts}$		--	4.56	--	mJ
Turn-on delay time	$t_{d(on)}$	$V_{CE}=400V, I_C=75A, R_g=5\Omega, V_{GE}=15V,$ 感性负载, $T_j=175^{\circ}C$	--	37	--	nS
Rise time	$t_r$		--	119	--	nS
Turn-off delay time	$t_{d(off)}$		--	169	--	nS
Fall time	$t_f$		--	147	--	nS
Turn-on energy	$E_{on}$		--	2.69	--	mJ
Turn-off energy	$E_{off}$		--	2.33	--	mJ
Total switching energy	$E_{ts}$		--	5.02	--	mJ
Gate charge	$Q_g$	$V_{CE}=520V, I_C=75A, V_{GE}=15V$	--	187	--	nC

Parameter	Symbol	Test Condition	Value			Units
			Min	Typ	Max	
<b>Diode Characteristic</b>						
Diode forward voltage	$V_F$	$I_F=75A, T_j=25^\circ C$	--	1.7	2.4	V
		$I_F=75A, T_j=175^\circ C$	--	1.3	--	V
Diode reverse recovery time	$t_{rr}$	$I_F=40A, di/dt=100A/uS$	--	105	--	nS
Diode peak reverse recovery current	$I_{RRM}$		--	2.2	--	A
Diode reverse recovery charge	$Q_{rr}$		--	126	--	nC

Notes:

1. Pulse duration is limited by  $T_{j,max}$

### 5 Typical Characteristic Curves

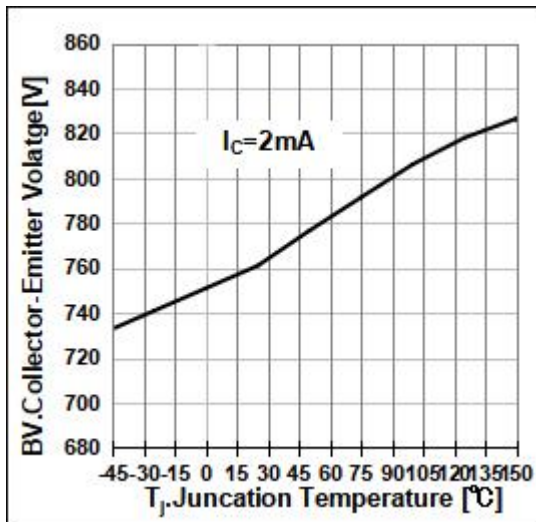

Fig1. Collector-Emitter Breakdown Voltage Temperature characteristic

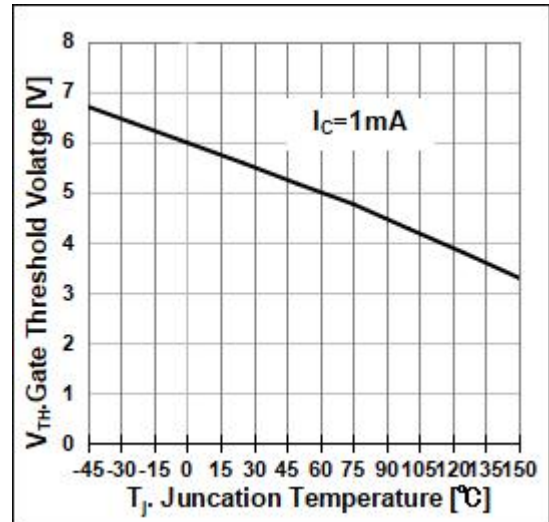

Fig2. Gate Threshold Voltage Temperature characteristic

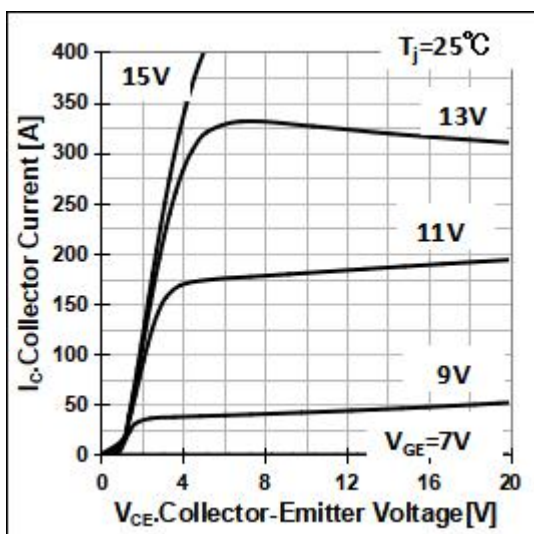

Fig3. Typical output characteristic

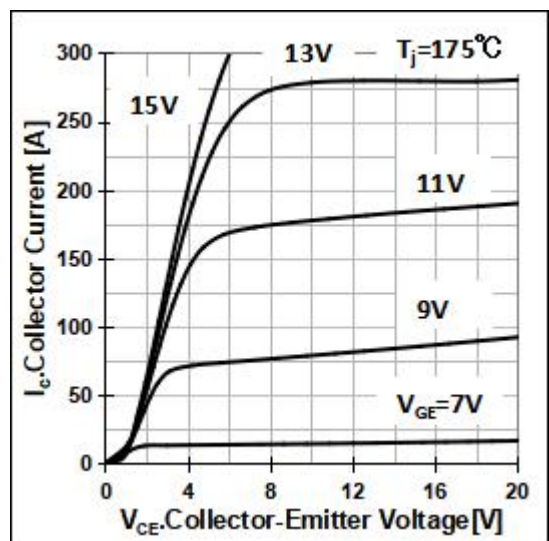

Fig4. Typical output characteristic

**5 Typical Characteristic Curves(Continue)**

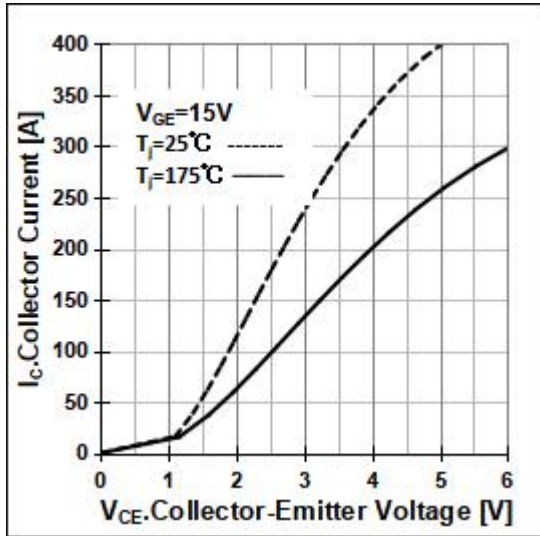

Fig5. Collector-emitter saturation voltage  
Characteristic

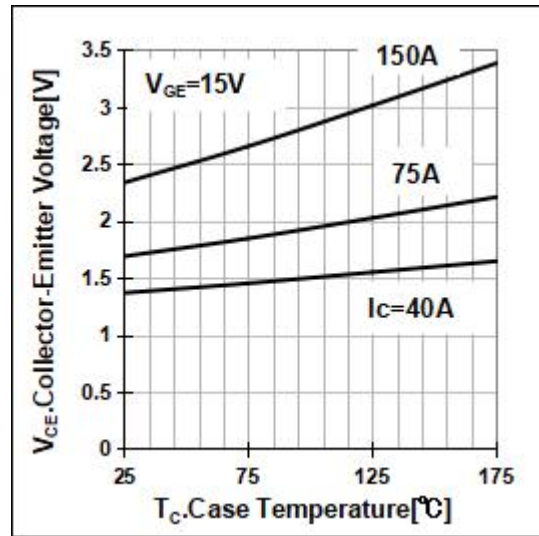

Fig6. Collector-emitter saturation voltage  
Temperature Characteristic

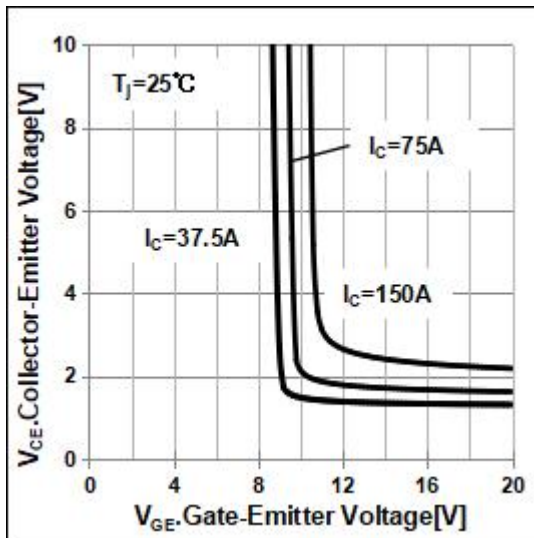

Fig7. Typical Transfer characteristic curve of  
Saturation Voltage vs Vge

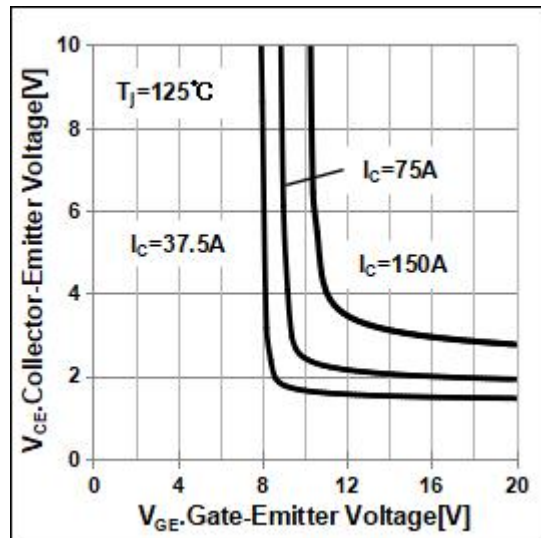

Fig8. Typical Transfer characteristic curve of  
Saturation Voltage vs Vge

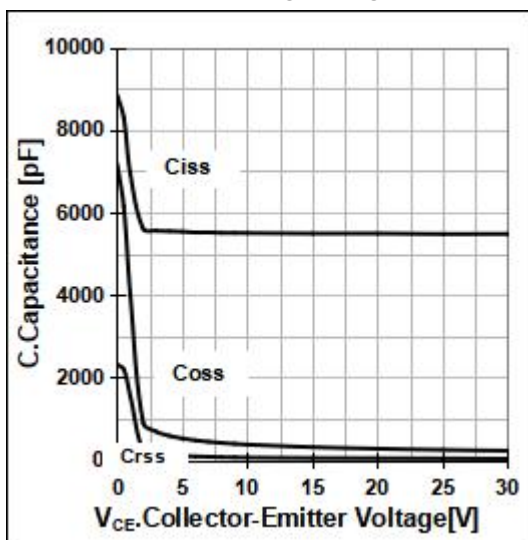

Fig9. Typical capacitance as a function of  
collector-emitter voltage

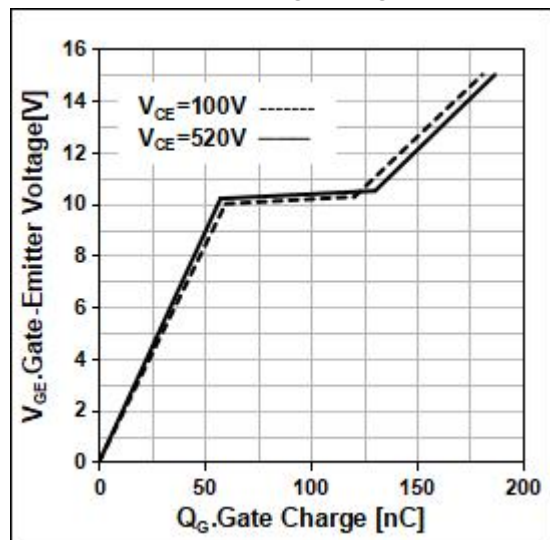

Fig10. Typical gate charge

**5 Typical Characteristic Curves(Continue)**

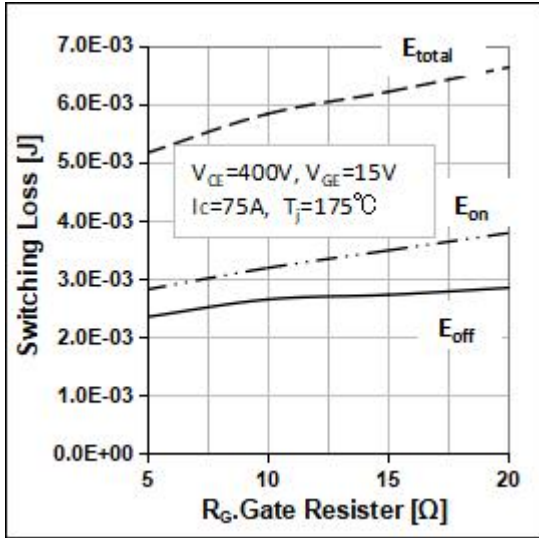

Fig11. Typical switching energy losses as a function of gate resistor

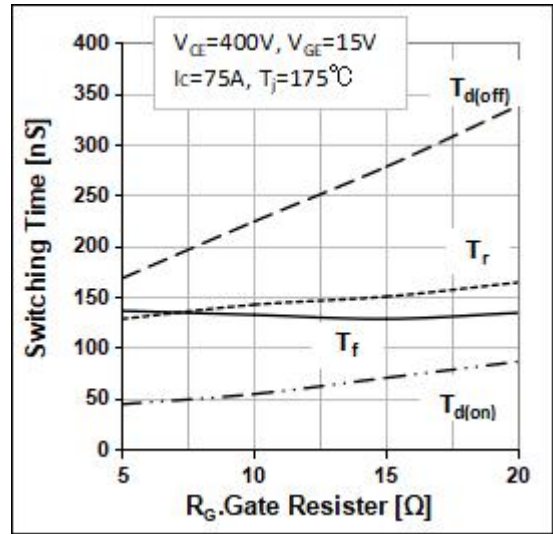

Fig12. Typical switching times as a function of gate resistor

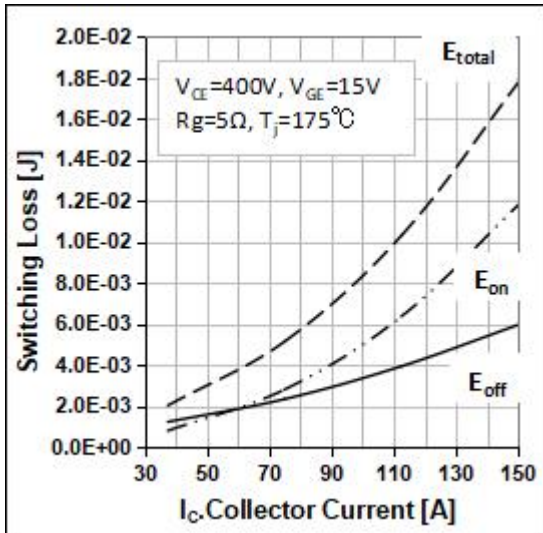

Fig13. Typical switching energy losses as a function of Collector Current

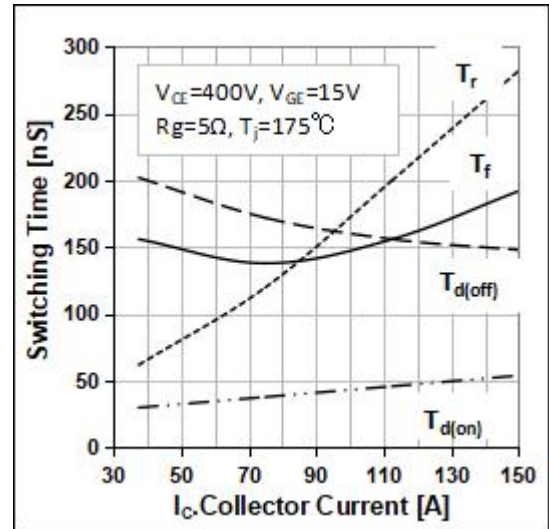

Fig14. Typical switching times as a function of Collector Current

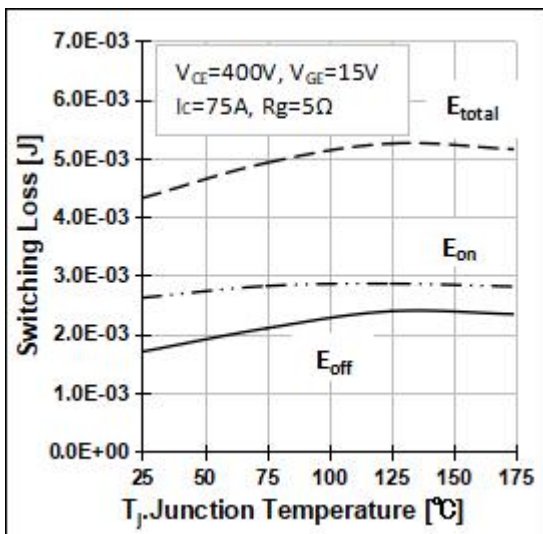

Fig15. Typical switching energy losses as a function of Junction temperature

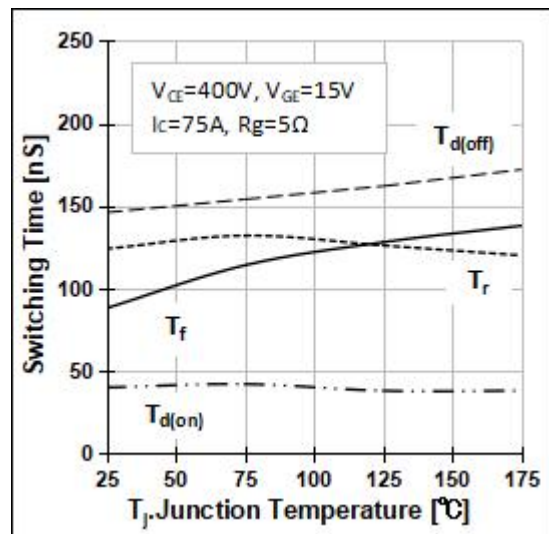

Fig16. Typical switching times as a function of Junction temperature

**5 Typical Characteristic Curves(Continue)**

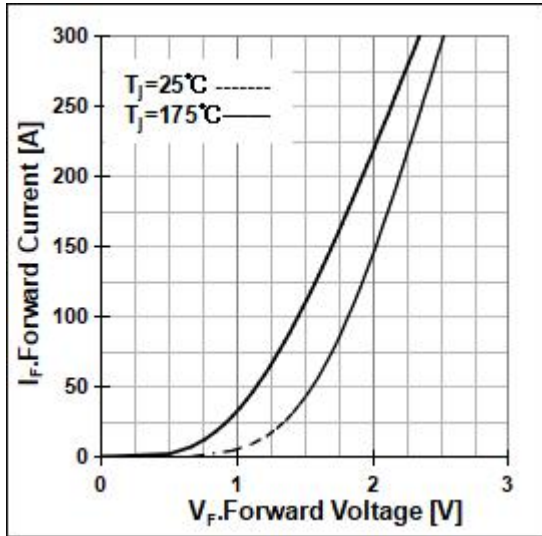

Fig17. Typical diode forward current as a function of forward voltage

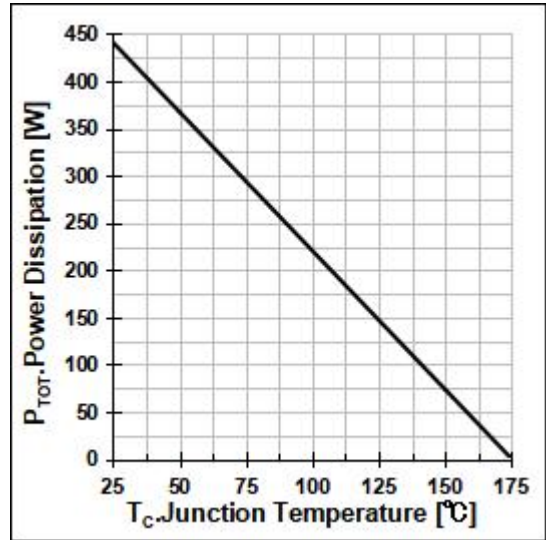

Fig18. Power dissipation temperature characteristic

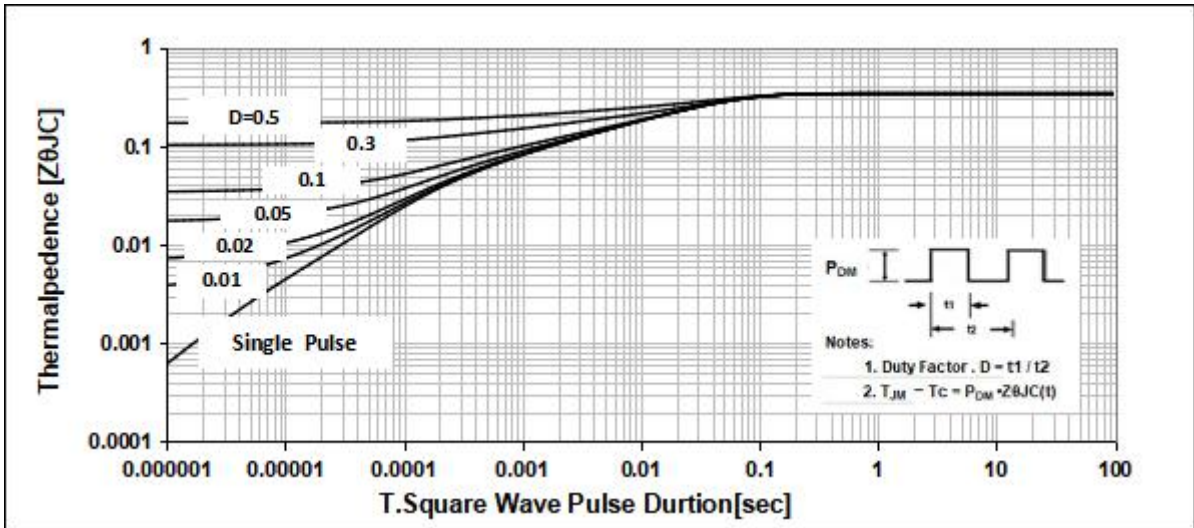
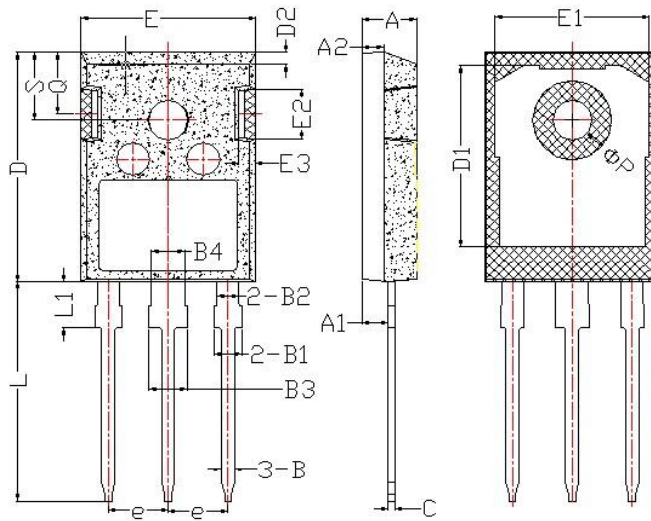

Fig19. IGBT transient thermal resistance

6 Dimensions (TO-247-3L)



项 目	规范(mm)		项 目	规范(mm)	
	MIN	MAX		MIN	MAX
A	4.60	5.20	E	15.50	16.10
A1	2.20	2.60	E1	13.00	14.70
B	0.90	1.40	E2	3.80	5.30
B1	1.75	2.35	E3	0.80	2.60
B2	1.75	2.15	e	5.20	5.70
B3	2.80	3.35	L	19.00	20.50
B4	2.80	3.15	L1	3.90	4.60
C	0.50	0.70	ΦP	3.30	3.70
D	20.60	21.30	Q	5.20	6.00
D1	16.00	18.00	S	5.80	6.60

7 Attentions

- Jiangsu Donghai Semiconductor CO.,LTD. reserves the right to change the specification without prior notice! The customer should obtain the latest version of the information before making the order and verify that the information is complete and up to date.
- It is the responsibility of the purchaser for any failure or failure of any semiconductor product under certain conditions. It is the responsibility of the purchaser to comply with safety standards and to take safety measures in the system design and machine manufacturing of Donghai products in order to avoid potential risk of failure. Injury or property damage.
- Product promotion is endless, our company will be dedicated to provide customers with better products.

## 8 Appendix

Revision history:

Date	REV.	Description	Page
2022.09.22	1.0	Original	
2023.02.17	1.1	Update switching curve	Page 5