



**Customer Part No:**

**Brighttek Part No:** 1SC3527W32F0WA0Q

1SC3527W52F0WACL

1SC3527W52F0WACE

**Specification:** TD0120A20E20C70

**Documents No:** BT-27-1103001

**Prepared By:** Yan Qun Zhang

**Check By:** Huan Huan Yi

**Time:** 2011/05/30

**Customer Confirmation:**



**Features**

- § forward current  $\leq 30\text{mA}$
- § Wide viewing angle:  $120^\circ$
- § Operating Temperature  $-40\sim 80^\circ\text{C}$
- § Storage temperature  $-40\sim 100^\circ\text{C}$
- § ROHS and REACH-compliant
- § outline(L\*W\*H) of  $3.5*2.7*1.0\text{mm}$
- § Qualified according to JEDEC moisturevity Level 3
- § PACKAGE:4000 PCS/REEL.
- § Chip material: InGaN
- § Reverse Voltage:5V

**Catalog**

Electrical-Optical Characteristics.....	2-3
Color coordinate Comparison .....	4-6
Optical Characteristics .....	7-9
Outline Dimensions .....	10
Reflow Profile .....	11
Packing .....	12-13
Test circuit and handling precautions .....	14
Collet .....	15



## Electrical-Optical Characteristics (Ta=25°C)

◆ **Cool--white**

Parameter	Symbol	Value			Unit	Test condition
		Min.	Typ.	Max.		
Forward Voltage	Vf	2.8	3.3	3.6	V	If=20mA
	IV	2050	2450	2650	Mcd	If=20mA
Lumen	Φ	6	7.0	7.5	lm	If=20mA
Wavelength	X	---	0.3176	---	---	If=20mA
	Y	---	0.3261	---	---	
Reverse Current	Ir	---	---	10	μA	Vr=5V
Viewing angle	2θ 1/2	---	120	---	Deg	If=20mA
Color Rendering Index	CRI		70	---	%	If=20mA
Color Temperature	CCT		6000		K	If=20mA

1.Luminous intensity (IV) ±10%, Forward Voltage (VF) ±0.1V, Wavelength(X,Y) ±0.01, CRI±5.

2.IS standard testing

◆ **Natural--white**

Parameter	Symbol	Value			Unit	Test condition
		Min.	Typ.	Max.		
Forward Voltage	Vf	2.8	3.3	3.6	V	If=20mA
	IV	2050	2450	2650	Mcd	If=20mA
Lumen	Φ	6	7.0	7.5	lm	If=20mA
Wavelength	X	---	0.3791	---	---	If=20mA
	Y	---	0.3798	---	---	
Reverse Current	Ir	---	---	10	μA	Vr=5V
Viewing angle	2θ 1/2	---	120	---	Deg	If=20mA
Color Rendering Index	CRI		70	---	%	If=20mA
Color Temperature	CCT		4240		K	If=20mA

1.Luminous intensity (IV) ±10%, Forward Voltage (VF) ±0.1V, Wavelength(X,Y) ±0.01, CRI±5.

2.IS standard testing



Parameter	Symbol	Value			Unit	Test condition
		Min.	Typ.	Max.		
Forward Voltage	Vf	2.8	3.3	3.6	V	If=20mA
	IV	2050	2250	2650	Mcd	If=20mA
Lumen	Φ	6	6.5	7.5	lm	If=20mA
Wavelength	X	---	0.4403	---	---	If=20mA
	Y	---	0.4047	---	---	
Reverse Current	Ir	---	---	10	μA	Vr=5V
Viewing angle	2θ 1/2	---	120	---	Deg	If=20mA
Color Rendering Index	CRI	---	70	---	%	If=20mA
Color Temperature	CCT		2960		K	If=20mA

1.Luminous intensity (IV) ±10%, Forward Voltage (VF) ±0.1V, Wavelength(X,Y) ±0.01, CRI±5.

2.IS standard testing

### High Power Product Identification Code

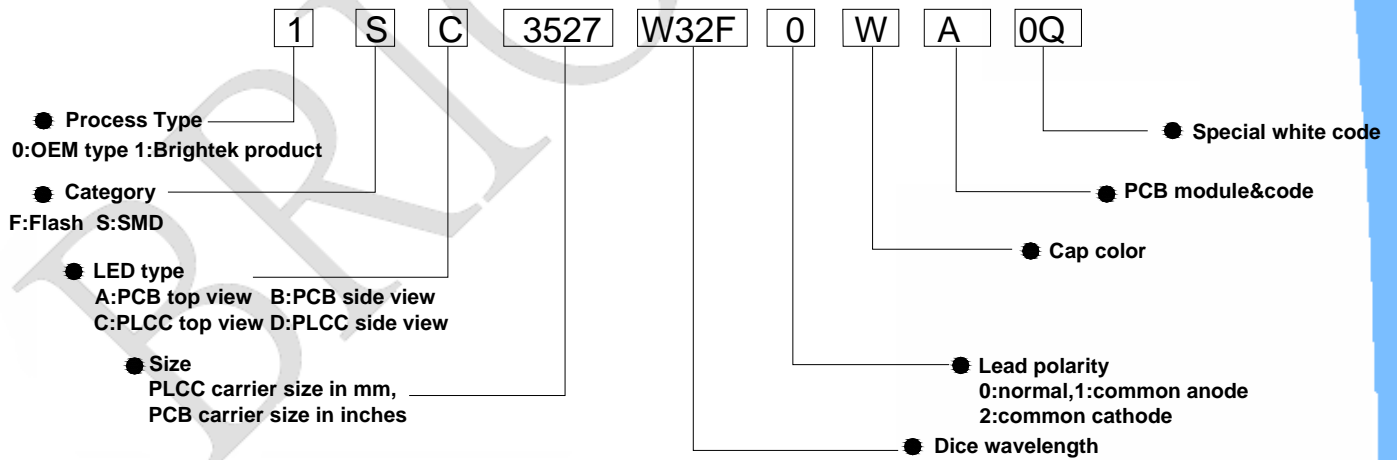

### Range of bins

Bin	B	C	D	E	F	G	H
VF(v)	2.8-2.9	2.9-3.0	3.0-3.1	3.1-3.2	3.2-3.3	3.3-3.4	3.4-3.5
Bin	I						
VF(v)	3.5-3.6						
Bin	6	7	8				
IV(Mcd)	2050-2250	2250-2450	2450-2650				



1SC3527W32F0WA0Q

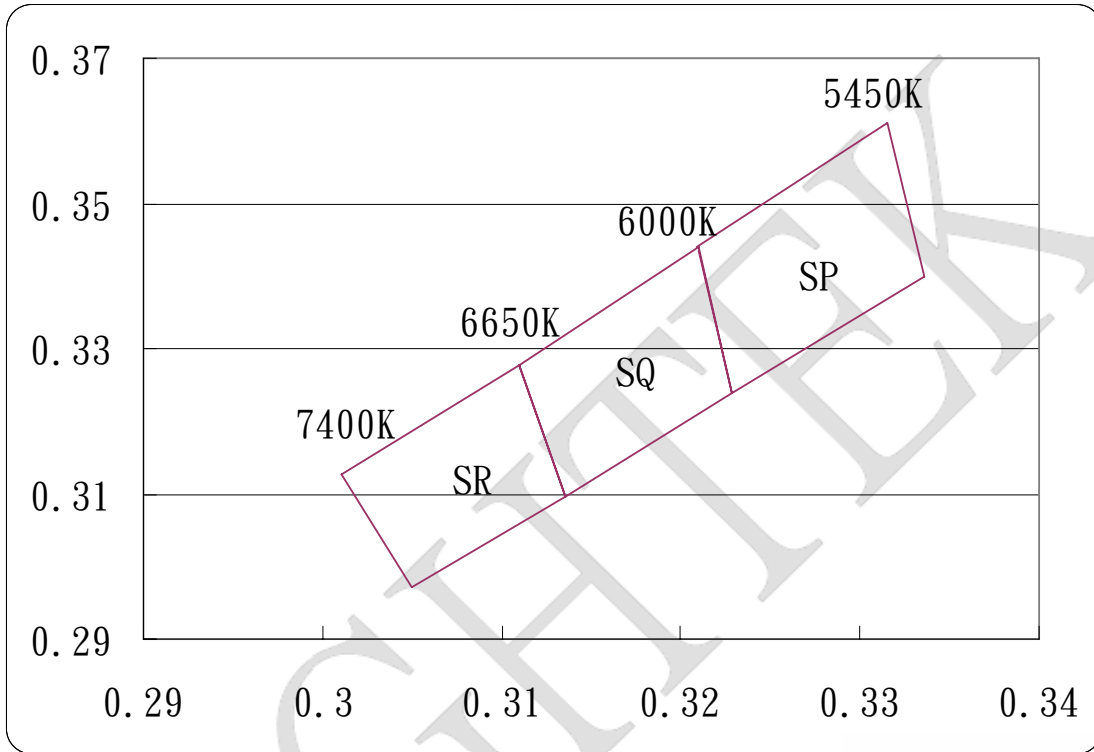

Bin Code	X	Y	X	Y	X	Y	X	Y
SR	0.3011	0.3127	0.305	0.2972	0.3136	0.3095	0.311	0.3276
SQ	0.311	0.3276	0.3136	0.3095	0.3229	0.324	0.3214	0.344
SP	0.3214	0.344	0.3229	0.324	0.3336	0.34	0.334	0.364



1SC3527W52F0WACL

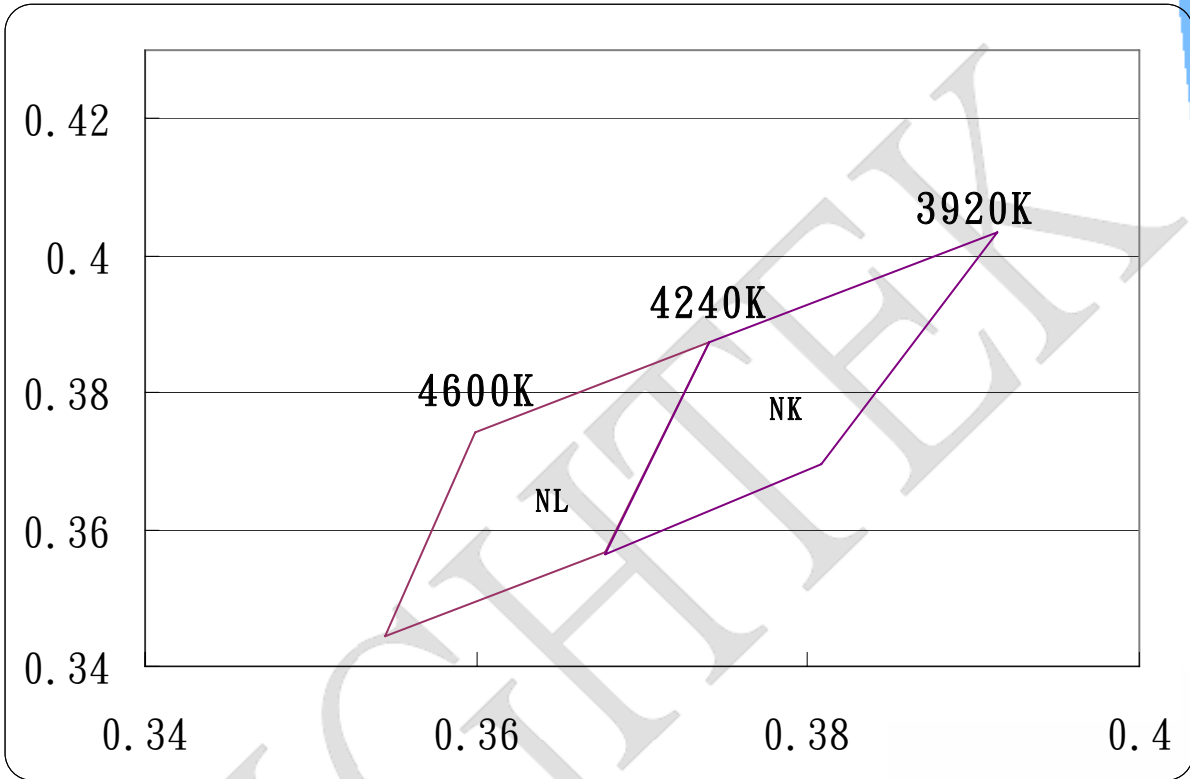

Bin Code	X	Y	X	Y	X	Y	X	Y
NL	0.3599	0.3742	0.3545	0.3443	0.3678	0.3567	0.3741	0.3872
NK	0.3741	0.3873	0.3678	0.3563	0.3808	0.3696	0.3914	0.4034



1SC3527W52F0WACE

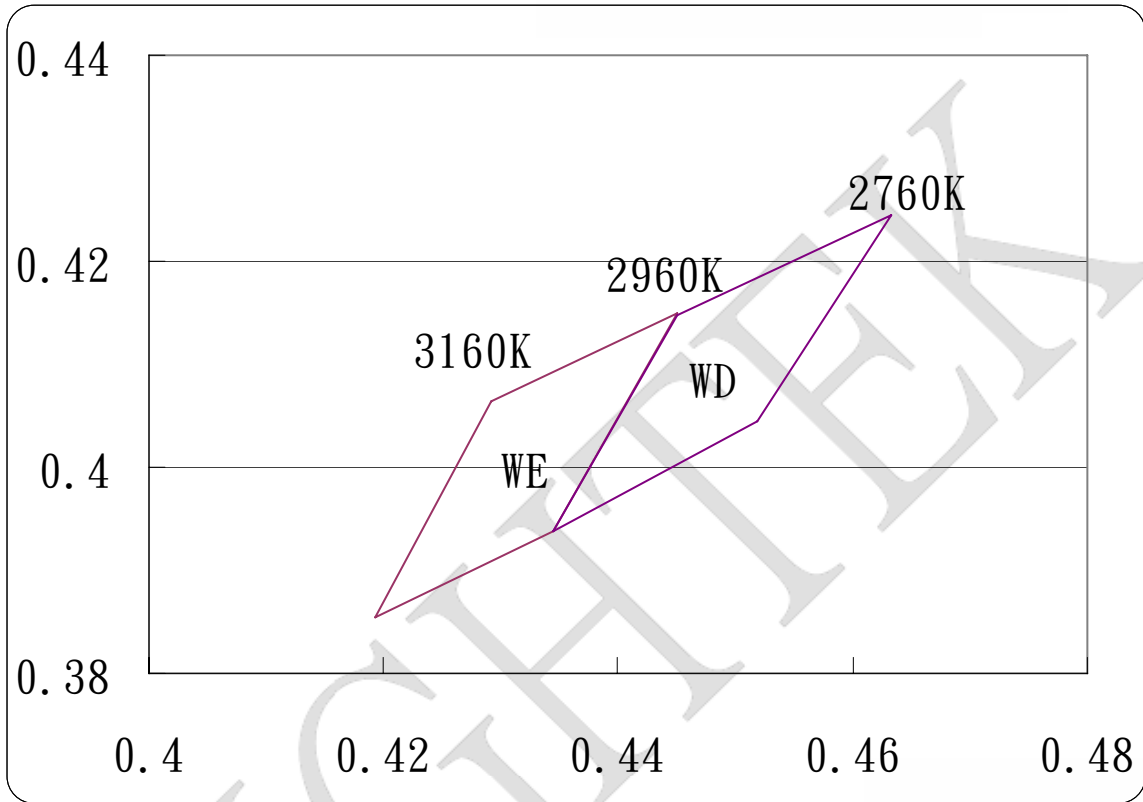

Bin Code	X	Y	X	Y	X	Y	X	Y
WE	0.4292	0.4064	0.4193	0.3855	0.4344	0.3937	0.4451	0.4149
WD	0.4451	0.4147	0.4344	0.3937	0.4519	0.4044	0.4633	0.4245



**Relative Spectral Power Distribution**

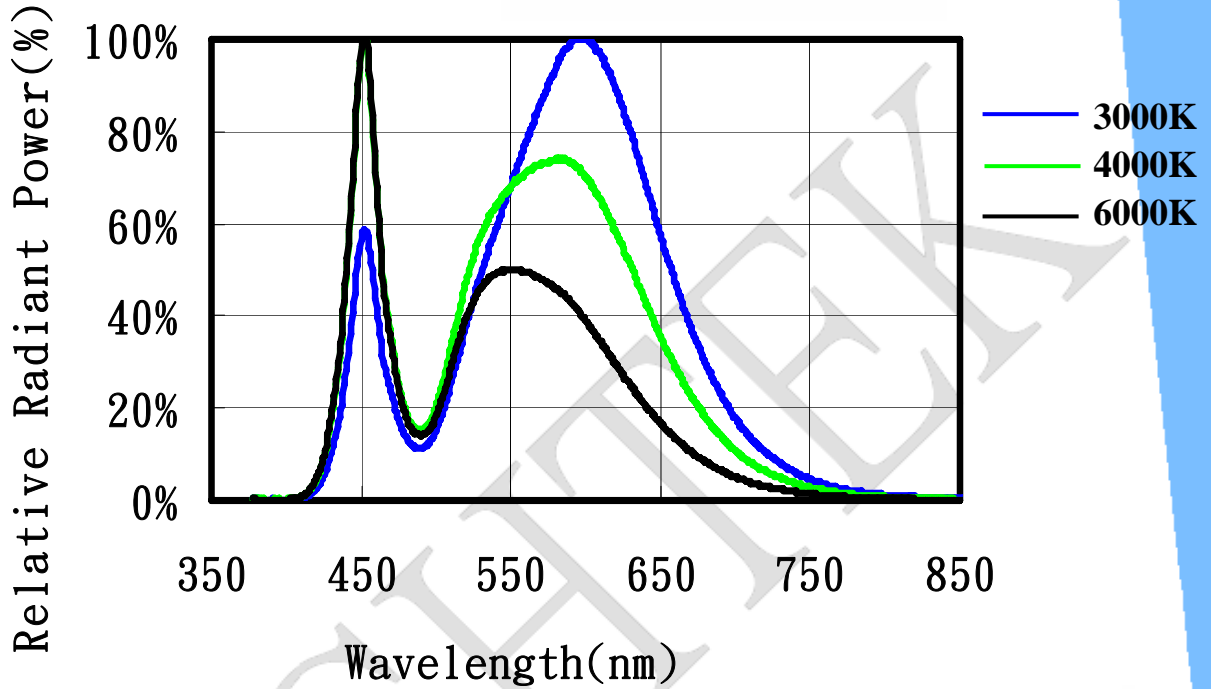

**Typical Spatial Distribution**

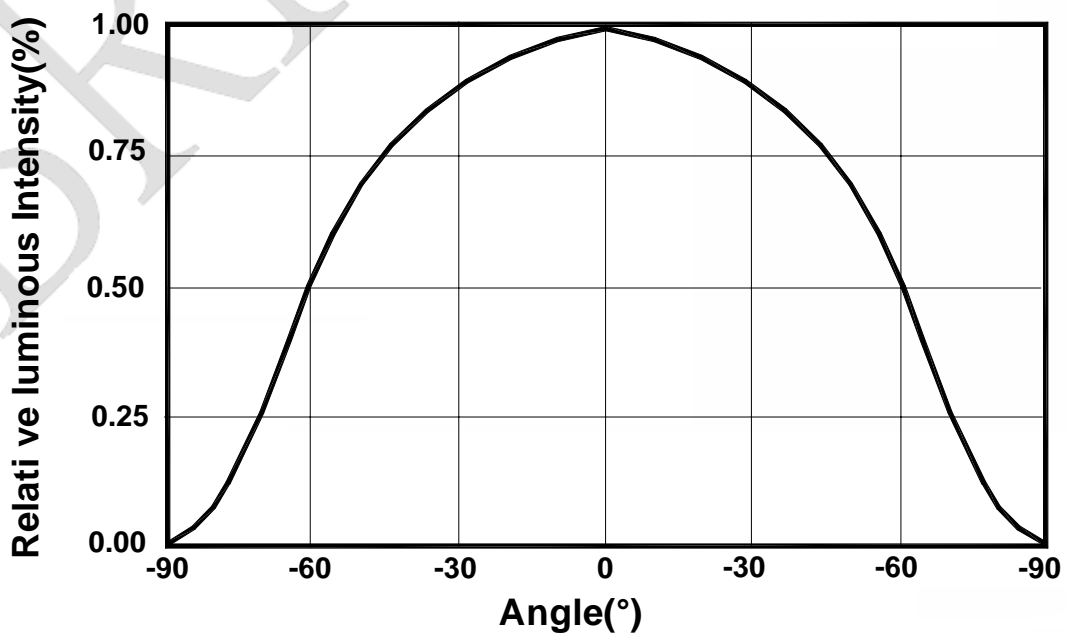



Relative Luminous Flux .Current

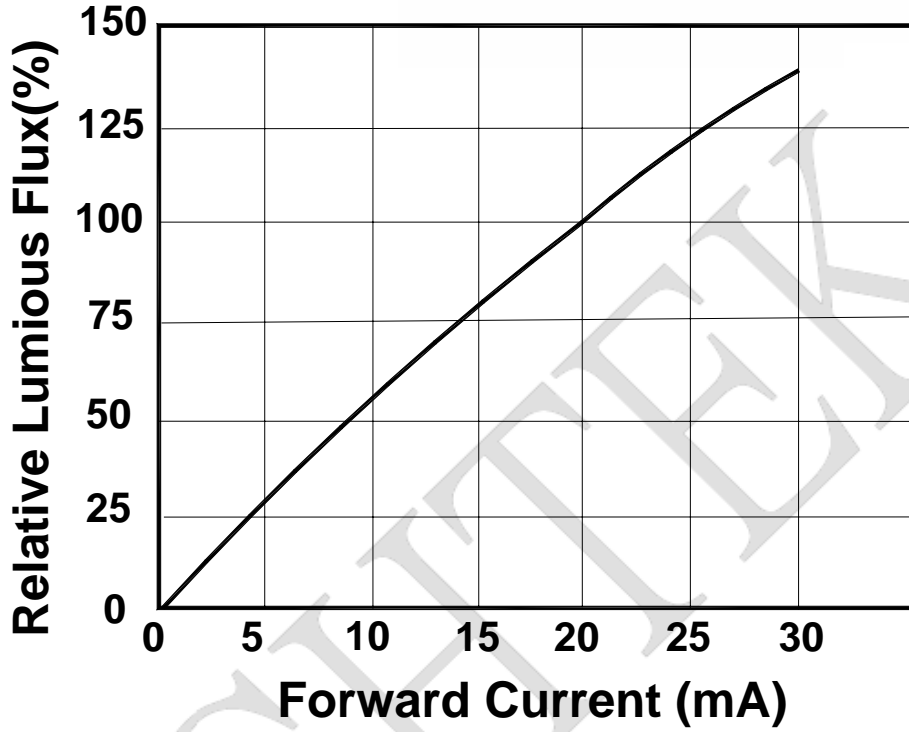

Relative Luminous Flux .Ambient Temperature

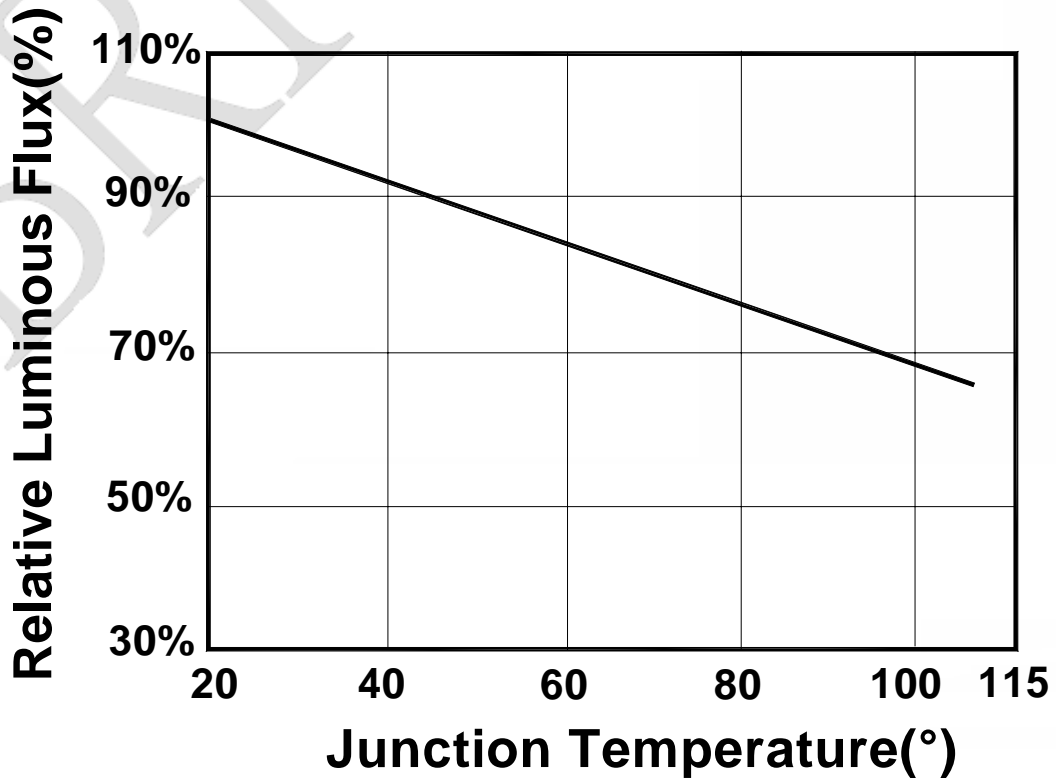





### Electrical Characteristics

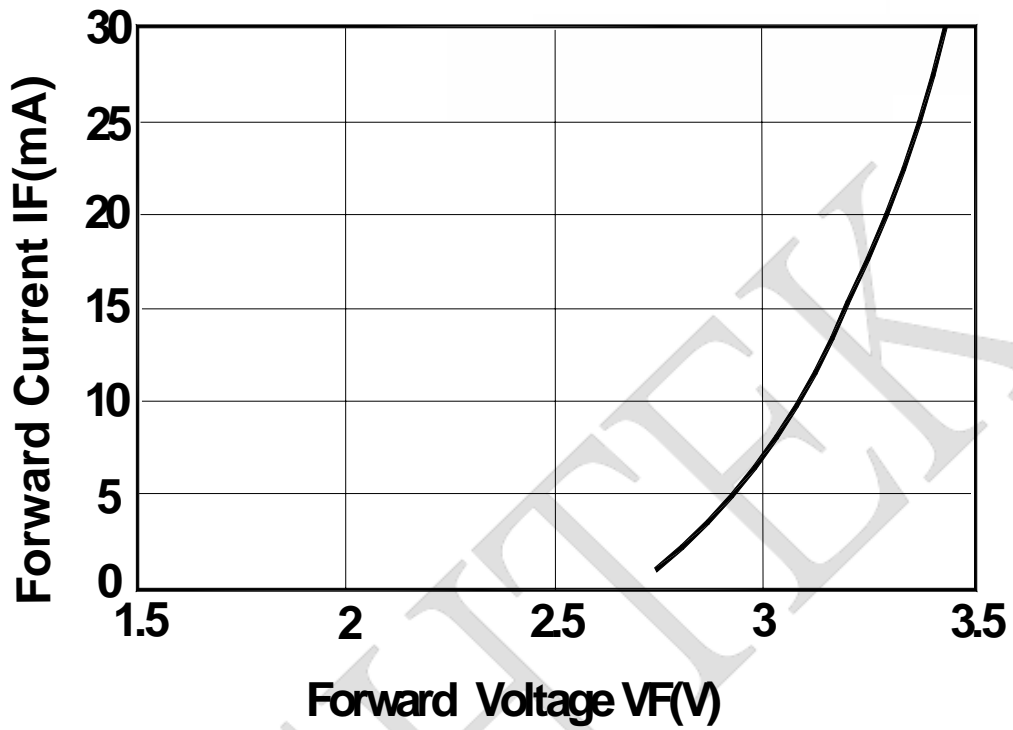

### Thermal Design

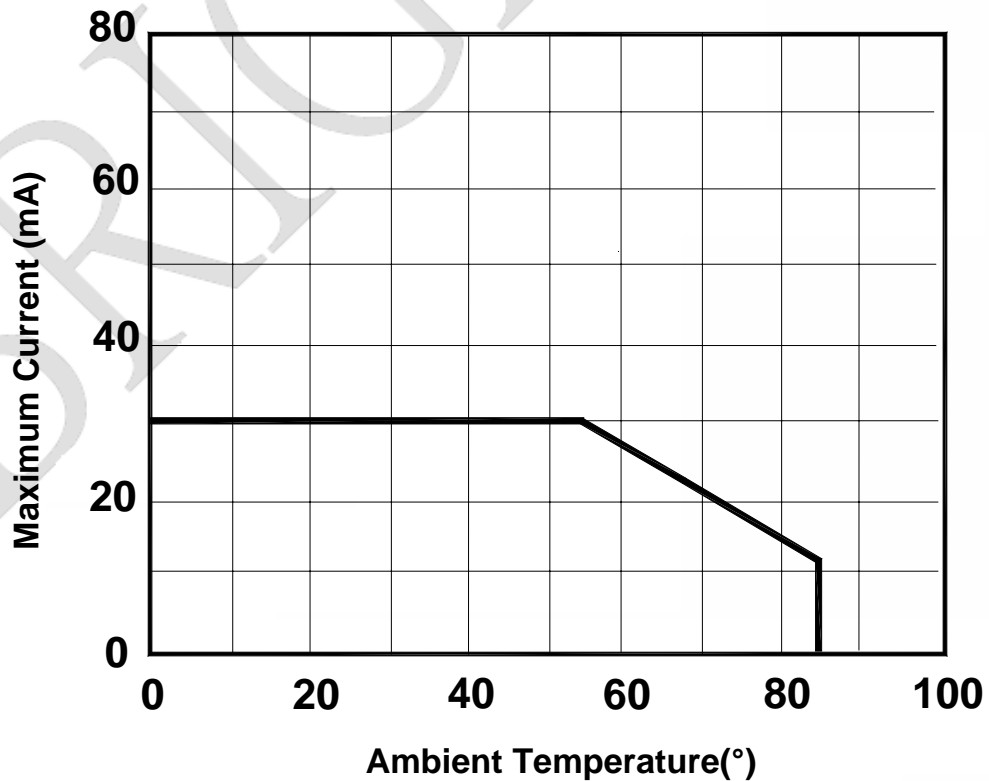



### Outline Dimensions

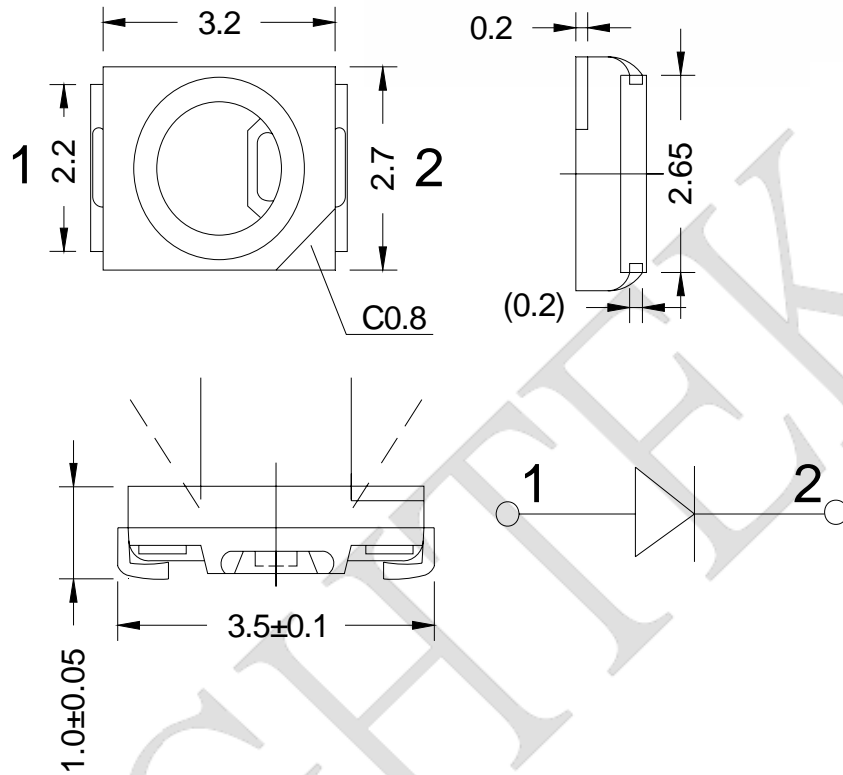

### RECOMMEND PADLAYOUT

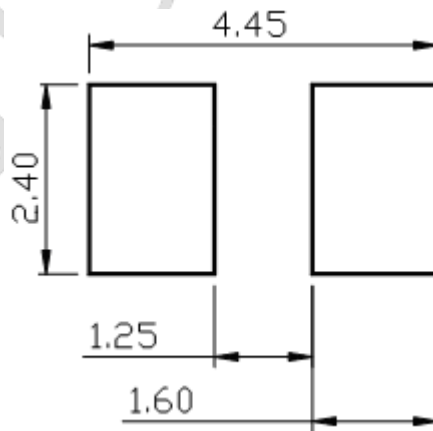

- § All dimensions are in millimeters.
- § Tolerance is  $\pm 0.1$  mm unless other specified
- § Specifications are subject to change without notice.



## Reflow Profile

### IR reflow soldering Profile

Lead Free solder

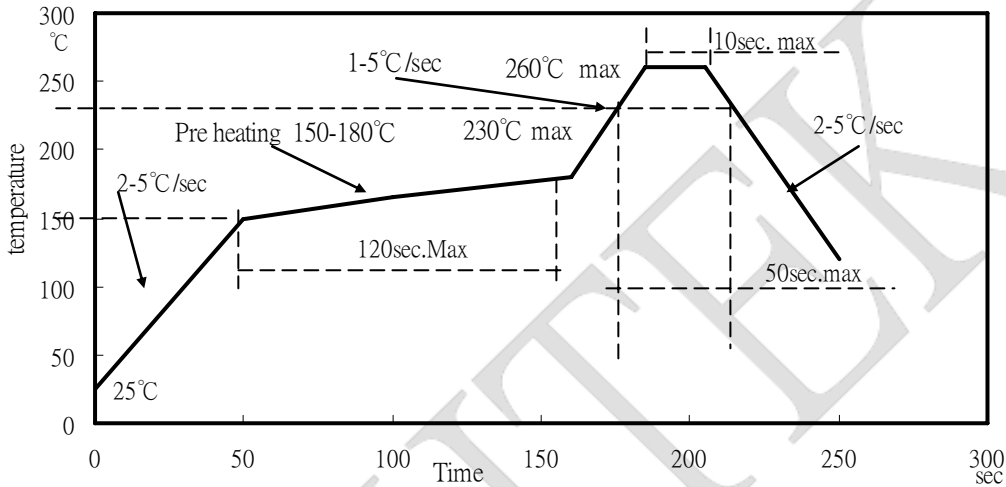

### IR reflow soldering Profile

Lead solder

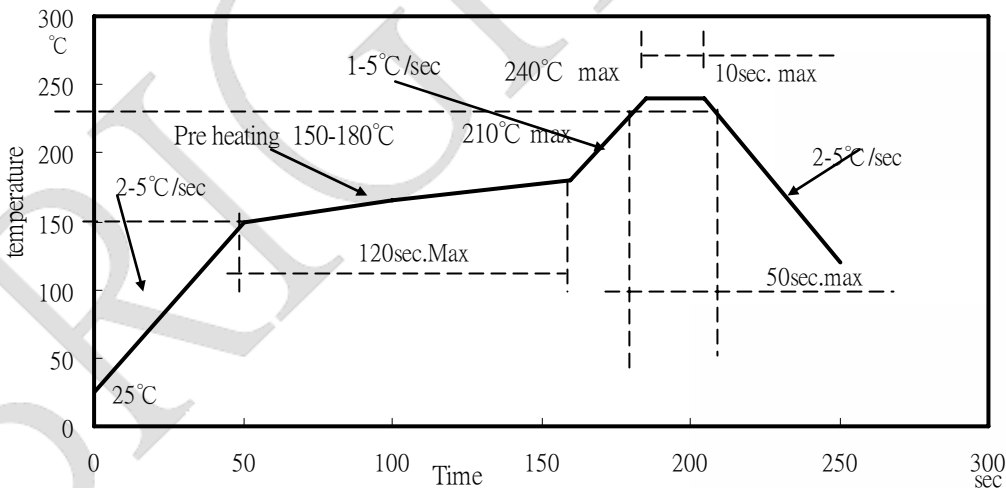

#### NOTES:

1. We recommend the reflow temperature 240°C ( $\pm 5^\circ\text{C}$ ). the maximum soldering temperature should be limited to 260°C.
2. Don't cause stress to the silicone resin while it is exposed to high temperature.
3. Number of reflow process shall be 1 time.



## 3527Single-Color High Performance SMD Top LEDs Packaging Specifications

### ● Dimensions of Reel (Unit: mm)

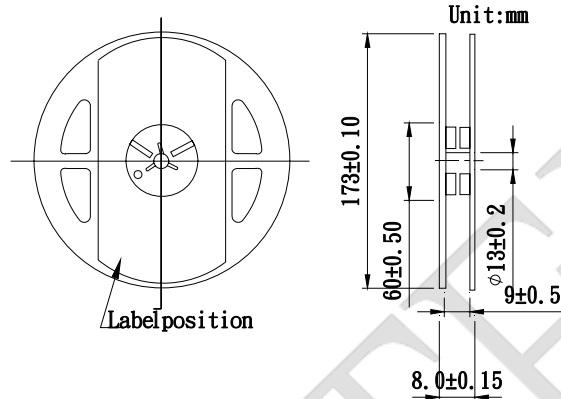

### ● Dimensions of Tape (Unit: mm)

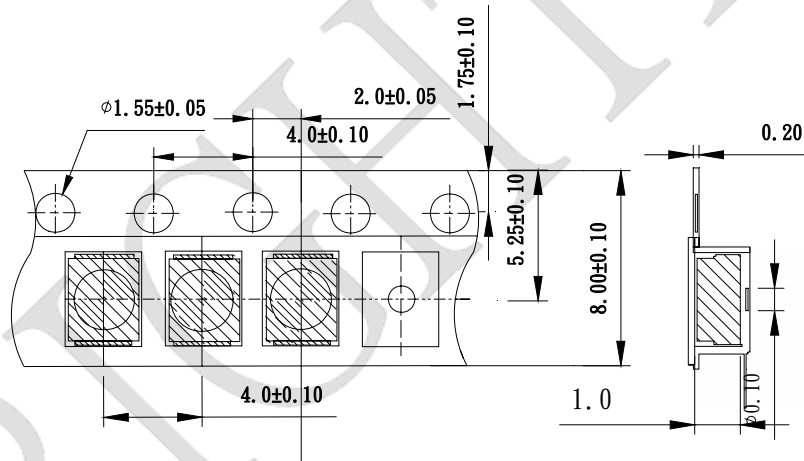

### ● Arrangement of Tape

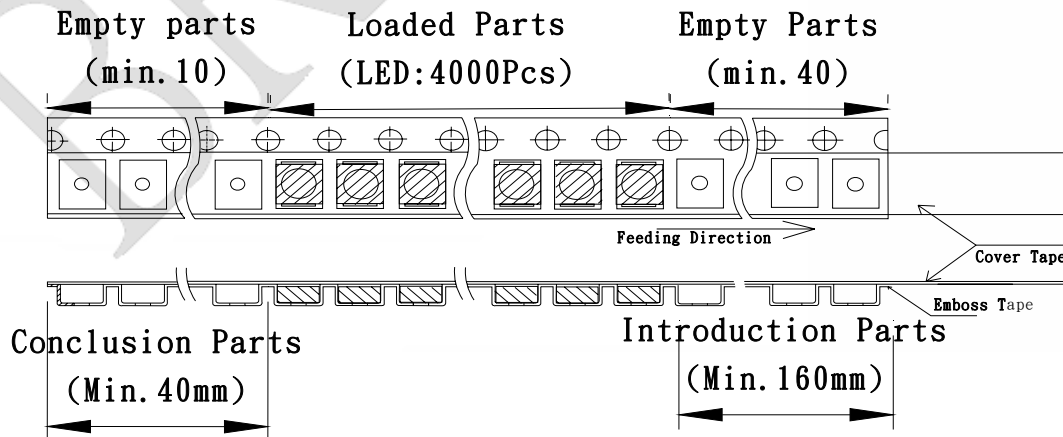

### NOTES

1. Empty component pockets are sealed with top cover tape;
2. The maximum number of missing smd is two;
3. The cathode is oriented towards the tape sprocket hole in accordance with ANSI/EIA RS-481 specifications;
4. 4,000pcs/Reel



## 3527 Single-Color High Performance SMD Top LEDs Packaging Specifications

- Packaging specifications

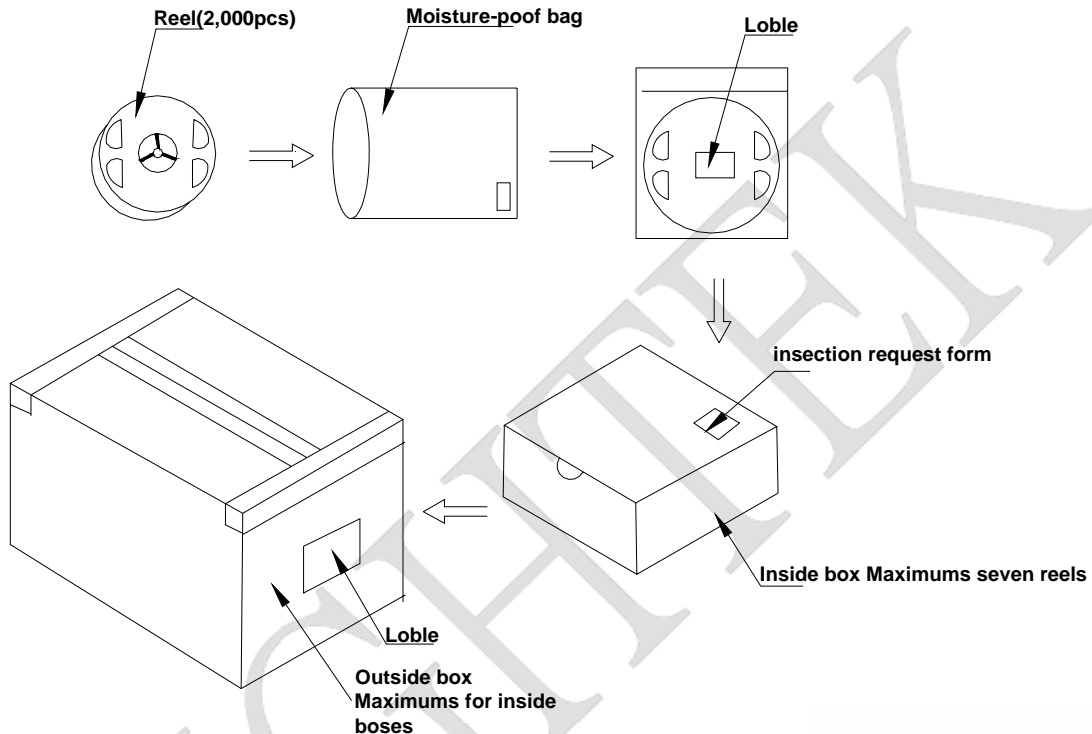

### NOTES:

Reeled products (The most numbers of products are 4,000pcs) packed in a seal off moisture-proof bag along with a desiccant one by one, Seven moisture-proof bag of maximums (total maximum number of products are 28,000pcs) packed in an inside box (size: about 238mm x about 194mm x about 102mm) and four inside boxes of maximums are put in the outside box (size: about 410mm x about 254mm x about 229mm) Together with buffer material, and it is packed. (Part No., Lot No., quantity should appear on the label on the moisture-proof bag, part No. And quantity should appear on the insertion request form on the cardboard box.) .



## Test circuit and handling precautions

### ■ Test circuit

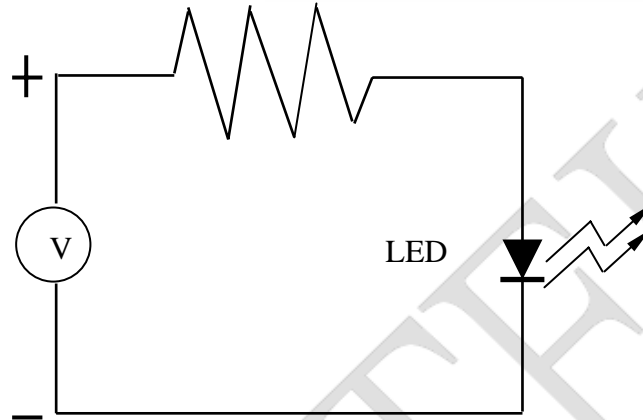

### ■ Handling precautions

#### 1. Over-current-proof

Customer must apply resistors for protection; otherwise slight voltage shift will cause big current change (Burn out will happen).

#### 2.Storage

2.1 It is recommended to store the products in the following conditions:

Humidity: 60% R.H. Max.

Temperature : 5°C ~30°C (41°F~86°F)

2.2 Shelf life in sealed bag: 12 month at < 5°C ~30°C and < 60% R.H. after the package is Opened, the products should be used within a week or they should be keeping to stored at  $\leq 20\%R.H.$  with zip-lock sealed.

#### 3.Baking

It is recommended to baking before soldering when the pack is unsealed after 24hrs. The Conditions are as followings:

3.1 70±3°C x 24hrs and < 5%RH, taped reel type

3.2 100±3°C x 2hrs , bulk type



## Collet

### 1、Abnormal situation caused by improper setting of collet

To choose the right collet is the key issue in improving the product's quality. LED is different from other electronic components, which is not only about electrical output but also for optical output. This characteristic made LED more fragile in the process of SMT. If the collet's lowering down height is not well set, it will bring damage to the gold wire at the time of collet's picking up and loading which will cause the LED fail to light up, light up now and then or other quality problems

### 2、How to choose the collet

During SMT, please choose the collet that has larger outer diameter than the lighting area of lens, in case that improper position of collet will damage the gold wire inside the LED. Different collets fit for different products, please refer to the following pictures cross out:

Outer diameter of collet should be larger than the lighting area

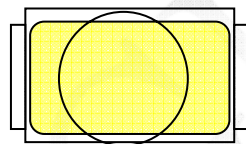

Picture 1 (✓)

Outer diameter of collet

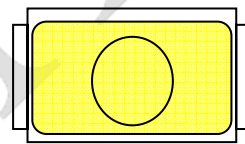

Picture 2 (✗)

### 3、How to set the height of collet

The reason why for top view SMD, the height of collet before it presses downward will directly affect the quality of products during SMT is that if the collect go down too much, it will press lens and cause the distortion or breaking of gold wire. The setting of collet position should follow the pictures belowed.

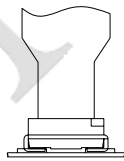

Picture 3 (✓)

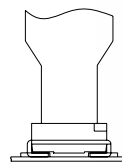

Picture 4 (✗)

### No.3、Other points for attention

- A、No pressure should be exerted to the epoxy shell of the SMD under high temperature.
- B、Do not scratch or wipe the lens since the lens and gold wire inside are rather fragile and cross out easy to break.
- C、LED should be used as soon as possible when being taken out of the original package, and should be stored in anti-moisture and anti-ESD package.

### No.4、This usage and handling instruction is only for your reference.