

TD041SCANH DFN package isolated CAN Transceiver

Features

- Ultra-small, ultra-thin, chip scale DFN package
- Compatible with the "ISO 11898-2" standard
- I/O power supply range supports 3.3V and 5V microprocessors
- High isolation to 3750Vrms
- Bus-Pin ESD protection up to 15kV(HBM)
- Baud rate up to 1Mbps
- -40V to +40V bus fault protection
- >25kV/μs CMTI
- TXD dominant time-out function
- Low communication delay
- The bus supports maximum 110 nodes
- Industrial operating ambient temperature range:-40°C to +125°C
- Meet AEC-Q100 standards
- EN62368 approval
- Moisture Sensitivity Level (MSL) 3

Applications

- Industrial automation, control, sensors and drive systems
- Building and greenhouse environmental control(HVAC) automation
- Security system
- Transport
- Medical treatment
- Telecommunication
- Can Bus standard such as CAN open, Device Net, NMEA2000, ARNIC825, ISO11783, CAN Kingdom, CAN aerospace

Functional Description

TD041SCANH is a isolated CAN bus transceiver, which is compliant with ISO11898-2 standard. The TD041SCANH provide differential transmitting and receiving capability between the CAN protocol controller and the physical layer bus. It is capable of running at data rates of up to 1 Mbps. The device has the function of series line, over-voltage, ground loss protection and thermal shutdown so that it is especially suitable for working in harsh environment. The rated operating temperature range of TD041SCANH is -40°C to 125°C.

Package

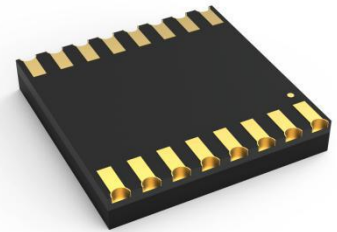

Contents

1 Home.....1	4 Characteristic Curve.....5
1.1 Feature and Package.....1	4.1 Typical Performance Curve.....5
1.2 Applications.....1	4.2 Parameter Measurement Information.....6
1.3 Functional Description.....1	5 Product Working Description.....7
2 Pin Connection and Description.....2	6 Application Circuit.....7
3 IC Related parameters.....3	7 Suggestions for Power Supply.....8
3.1 Absolute Maximum Rating.....3	8 Order Information.....8
3.2 Recommended Operating Conditions.....3	9 Package Information.....8
3.3 Electrical Characteristics.....4	10 Tape & Reel Information.....9
3.4 Transmission Characteristics.....5	
3.5 Physical Information.....5	

Pin Connection

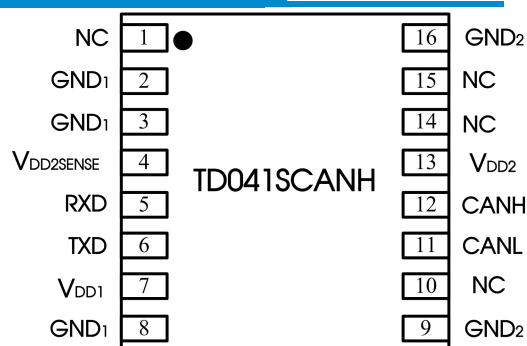

Note: All GND₁ pins are internally connected;
All GND₂ pins are internally connected.

Internal Block Diagram

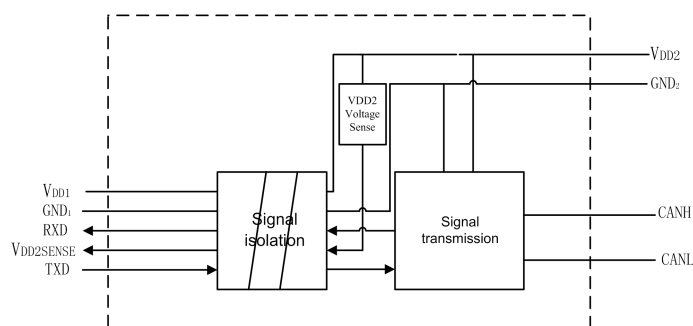

Function Table

Letter	Description
H	High-Level
L	Low-Level
I	Indeterminate
X	Unrelated
Z	High Impedance
NC	No Connection

Table 1. Driver Function table

Power		Input	Output			
V _{DD1}	V _{DD2}	TXD	Bus State	CANH	CANL	V _{DD2SENSE}
On	On	L	Dominant	H	L	L
On	On	H	Recessive	Z	Z	L
On	On	left floating	Recessive	Z	Z	L
Off	On	X	Recessive	Z	Z	I
On	Off	L	I	I	I	H

Table 2. Receiver Function table

Power		Input		Output	
V _{DD1}	V _{DD2}	V _{ID} = CANH - CANL	Bus State	RXD	V _{DD2SENSE}
On	On	≥ 0.9 V	Dominant	L	L
On	On	≤ 0.5 V	Recessive	H	L
On	On	0.5 V < V _{ID} < 0.9 V	I	I	L
On	On	OPEN	Recessive	H	L
Off	On	X	X	I	I
On	Off	X	X	H	H

Pin Descriptions

Pin Number	Pin Name	Pin Functions
1	NC	No Connect.
2	GND ₁	Ground(Logic side).
3	GND ₁	Ground(Logic side).
4	V _{DD2SENSE}	V _{DD2} Voltage Sense.
5	RXD	Receiver Output Data (L: Dominant Bus State; H: Recessive Bus State).
6	TXD	Driver Input Data (L: Dominant Bus State; H: Recessive Bus State).
7	V _{DD1}	Power Supply (Logic Side).
8	GND ₁	Ground(Logic side).
9	GND ₂	Ground (Bus Side).
10	NC	No Connect.
11	CANL	Low Level CAN Voltage Input/Output.
12	CANH	High Level CAN Voltage Input/Output.
13	V _{DD2}	Power Supply (Bus Side).
14	NC	No Connect.
15	NC	No Connect.
16	GND ₂	Ground (Bus Side).

Absolute Maximum Ratings

General test conditions: Free-air, normal operating temperature range (unless otherwise specified).

PARAMETERS		Min.	Max.	UNIT
V _{DD1} , V _{DD2}	Power Supply	-0.5	6	V
V _I	Input Voltage(TXD)	-0.5	V _{DD1} +0.5	V
V _{O(RXD)}	Output Voltage (RXD)	-0.5	V _{DD1} +0.5	V
V _{O(SENSE)}	Output Voltage (V _{DD2SENSE})	-0.5	V _{DD1} +0.5	V
V _{CANH} , V _{CANL}	Bus terminal voltage	-40	40	V
V _{REF}	Reference Voltage	-0.5	+6	V
T _A	Operating Temperature Range	-40	125	°C
T _{stg}	Storage Temperature Range	-50	150	°C
Reflow Soldering Temperature		Peak temp. ≤260°C, maximum duration ≤60s at 217°C. Please also refer to IPC/JEDEC J-STD-020D.3.		

Important: Exposure to absolute maximum rated conditions for an extended period may severely affect the device reliability, and stress levels exceeding the "Absolute Maximum Ratings" may result in permanent damage. All voltage values are referenced to the reference ground (GND).

Recommended Operating Conditions

Recommended Operating Conditions		Min.	Nom.	Max.	Unit
V _{DD1}	Power Supply(Logic Side)	2.375	3.3	5.5	V
V _{DD2}	Power Supply(Bus Side)	4.75	5	5.25	
V _I or V _{IC}	Voltage at any bus terminal (common mode)	-40		+40	
V _{IH}	High-level input voltage(TXD)	2			
V _{IL}	Low-level input voltage(TXD)			0.8	
I _{D1}	Input Static Current(Logic Side)	V _{DD1} = 5.5V, V _{DD2} = 5.25V, No Signal		3.5	mA
I _{D2}	Input Static Current(Bus Side)			10	
P _D	Power Dissipation	V _{DD1} = 5.5V, V _{DD2} = 5.25V, TA= 105°C, R _L = 60Ω; TXD Input Signal: f= 500kHz; Duty= 50%		200	mW
P _{D1}	Power Dissipation(Logic Side)			25	
P _{D2}	Power Dissipation(Bus Side)			175	
Signaling rate		40		1000	kbps

Electrical Characteristics

General test conditions and V_{DD1}=V_{DD2}= 5V, Ta = 25°C (unless otherwise specified).

PARAMETERS		CONDITIONS	Min.	Nom.	Max.	Unit
DRIVER						
V _{IH}	Input High Voltage	TXD pins, see Figure 11	2			V
V _{IL}	Input Low Voltage	TXD pins, see Figure 11			0.8	V
I _{IH} , I _{IL}	CMOS Input Current	TXD pins, see Figure 11			2	mA
V _{CANL} , V _{CANH}	Recessive Bus Voltage	V _{TXD} = high, R _L = ∞, see Figure 11	2.0		3.0	V
V _{CANH}	CANH Output Voltage	V _{TXD} = low, see Figure 11	2.75		4.5	V
V _{CANL}	CANL Output Voltage	V _{TXD} = low, see Figure 11	0.5		2	V
V _{OD}	Differential Output Voltage	V _{TXD} = low, R _L = 50 Ω, see Figure 11	1.5		3	V
		V _{TXD} = high, R _L = ∞, see Figure 11	-500		+50	mV
R _{TXD}	Internal TXD Pull up Resistor			9.1		kΩ
RECEIVER						
V _{IT+}	Positive-going input threshold voltage				900	mV
V _{IT-}	Negative-going input threshold voltage		500			mV
V _{HYS}	Hysteresis Voltage (V _{IT+} - V _{IT-})	See Figure 14		150		mV
R _{DIFF}	Differential input resistance		30		80	kΩ
V _{OL}	RXD Output Low Voltage	I _{OUT} = 1.5 mA		0.2	0.4	V
V _{OH}	RXD Output High Voltage	I _{OUT} = -1.5 mA	V _{DD1} -0.4	V _{DD1} - 0.2		V
C _I	Input capacitance to ground (CANH or CANL)	TXD at 3 V, V _I = 0.4 sin(4E6πt) + 2.5 V		13		pF
C _{ID}	Differential input capacitance	TXD at 3 V, V _I = 0.4 sin(4E6πt)		5		pF
Other						
V _{OL}	VDD2SENSE Output Low Voltage	I _{SENSE} = 1.5 mA		0.2	0.4	V
V _{OH}	VDD2SENSE Output High Voltage	I _{SENSE} = -1.5 mA	V _{DD1} -0.4	V _{DD1} - 0.2		V
V _{TH(SENSE)}	Bus Voltage Sense Threshold Voltage	V _{DD2} =100Hz	2.0		2.5	V
ESD	HBM	CANH, CANL and GND			±15	kV
		Other pins			±2	kV
	IEC/EN 61000-4-2 (Contact) Perf. Criteria B	CANH, CANL and GND			±2	kV
EFT	IEC61000-4-4: Perf. Criteria B	CANH, CANL and GND			±2	kV
Surge	IEC61000-4-5: Perf. Criteria B	CANH, CANL and GND(Common Mode)			±2	kV
V _{I-O}	Isolation Test	Leakage current <1mA.			3750	Vrms
R _{I-O}	Insulation Resistance	At 500VDC	1000			MΩ

C_{I-O}	Isolation Capacitor			3		pF
C_i	Input Capacitor			4		pF
CMTI	Common Mode Transient Immunity	TXD = V_{DD1} or 0 V, VCM = 1 kV, transient magnitude = 800 V	25			kV/ μ s

Transmission Characteristics

General test conditions and $V_{DD1}=V_{DD2}=5V$, $T_a = 25^\circ C$ (unless otherwise specified).

PARAMETERS		CONDITIONS	Min.	Nom.	Max.	Unit
t_{onTXD}	Propagation Delay TXD On to Bus Active	$R_L = 60 \Omega$, $C_L = 100 pF$, see Figure 13 and Figure 15			150	ns
t_{offTXD}	Propagation Delay TXD Off to Bus Inactive				200	ns
t_{onRXD}	Propagation Delay TXD On to Receiver Active				300	ns
t_{offRXD}	Propagation Delay TXD Off to Receiver Inactive				250	ns
t_{SE}	Enable Time, VDD2 High to VDD2SENSE Low			100	us	
t_{SD}	Disable Time, VDD2 Low to VDD2SENSE High			100	us	
t_{TXD_DTO}	Dominant time-out time	$C_L = 100 pF$	1.2		3.8	ms

Physical Specifications

PARAMETERS	Value	Unit
Weight	0.4(Typ.)	g

Typical Performance Curves

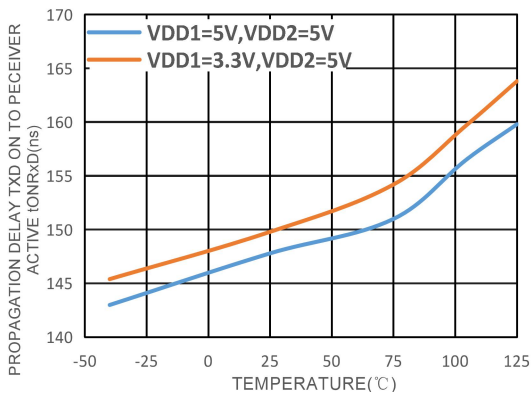

Figure3. Propagation Delay from TXD On to Receiver Active vs. Temperature

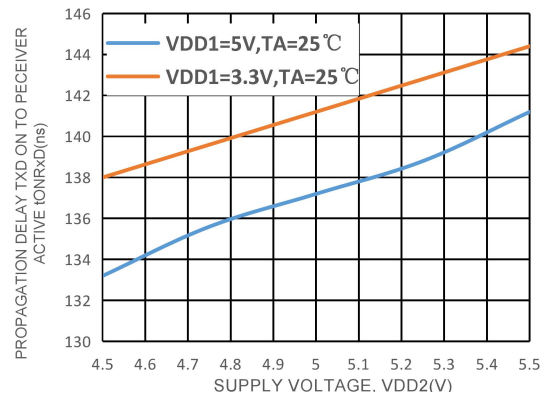

Figure4. Propagation Delay from TXD On to Receiver Active vs. Voltage, VDD2

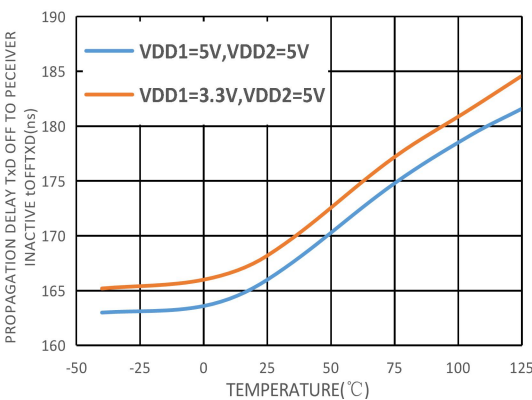

Figure5. Propagation Delay from TXD Off to Receiver Inactive vs. Temperature

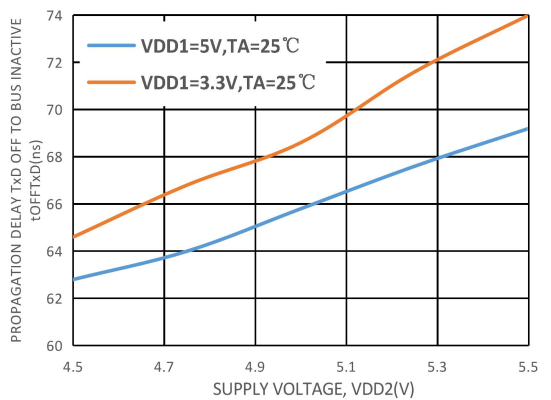

Figure6. Propagation Delay from TxD Off to Bus Inactive vs. Voltage, VDD2

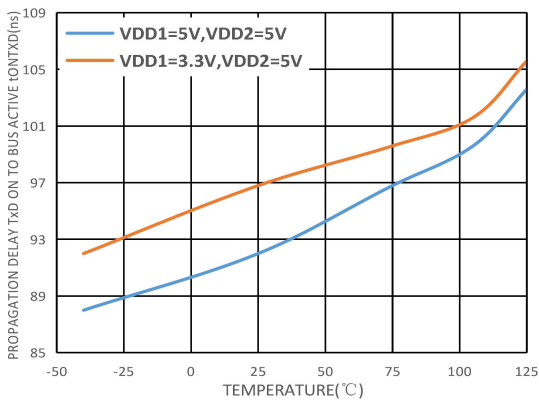

Figure 7. Propagation Delay from TXD On to Bus Active vs. Temperature

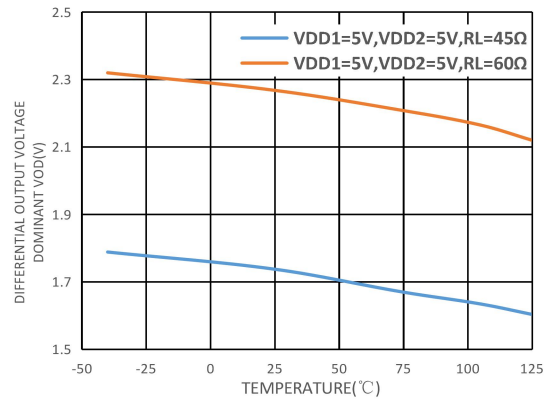

Figure 8. Drive Differential Output Voltage Dominant vs. Temperature

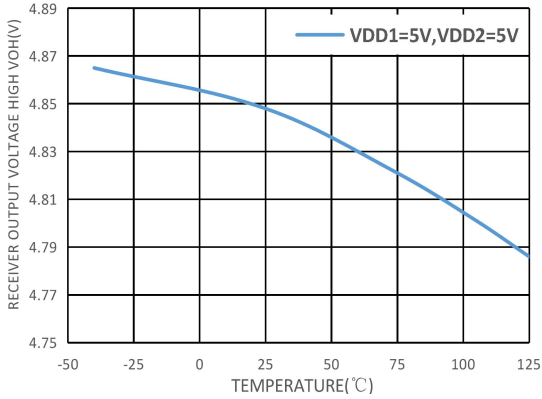

Figure 9. Receiver Output High Voltage vs. Temperature

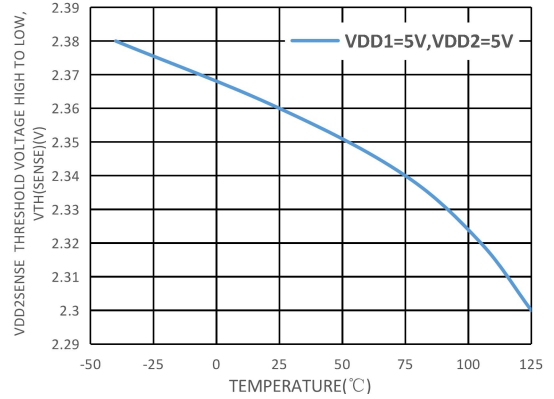

Figure 10. VDD2 Voltage Sense Threshold Voltage High to Low vs. Temperature

Test Circuits

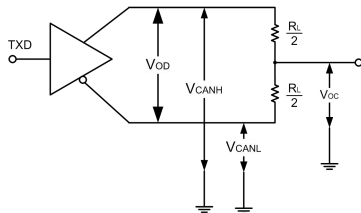

Figure 11. Driver Test Circuit

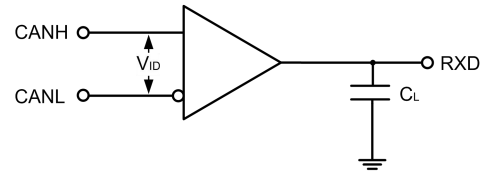

Figure 12. Receiver Test Circuit

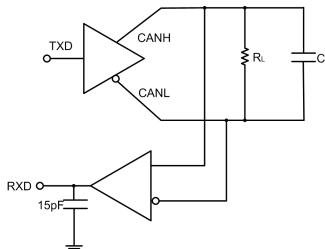

Figure 13. Switching Characteristics Test Circuit

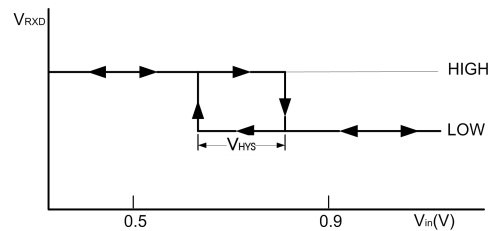

Figure 14. Receiver Input Hysteresis

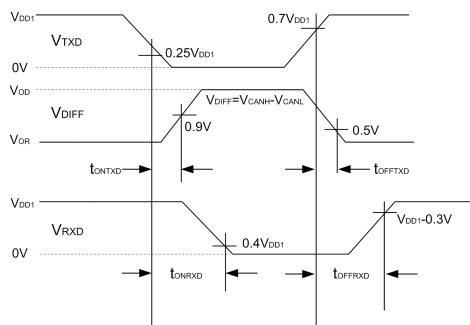

Figure 15. Drive and Receiver Propagation Drive

Detailed Description

TD041SCANH is a isolated CAN bus transceiver with the ability of differential signal transmission between the bus and CAN protocol controller, which is compliant with ISO11898-2 standard.

Short-circuit protection: TD041SCANH has current-limiting protection to prevent the drive circuit from short-circuiting to positive and negative supply voltages. The power dissipation increases when a short circuit occurs. The short-circuit protection function protects the driver stage from damage.

Over-temperature protection: TD041SCANH has over-temperature protection. When the over-temperature protection is triggered, the current in the driver stage will decrease. Because the drive tube is the primary energy consuming component, current reduction can reduce power consumption and reduce chip temperature. At the same time, the rest of the chip remains functional.

Dominant time-out function: TD041SCANH has dominant time-out function to prevent if the pin TXD is forced to a permanent low level due to a hardware or software application failure, the built-in TXD dominant timeout timer circuit prevents the bus line from being driven to a permanent dominant state (blocking all network traffic). The timer is triggered by the negative edge on pin TXD. If the low level on pin TXD lasts longer than the internal timer value (t_{TXD_DTO}), the transmitter will be disabled and the drive bus will enter a recessive state. The timer is reset by the positive edge on pin TXD.

Application circuit

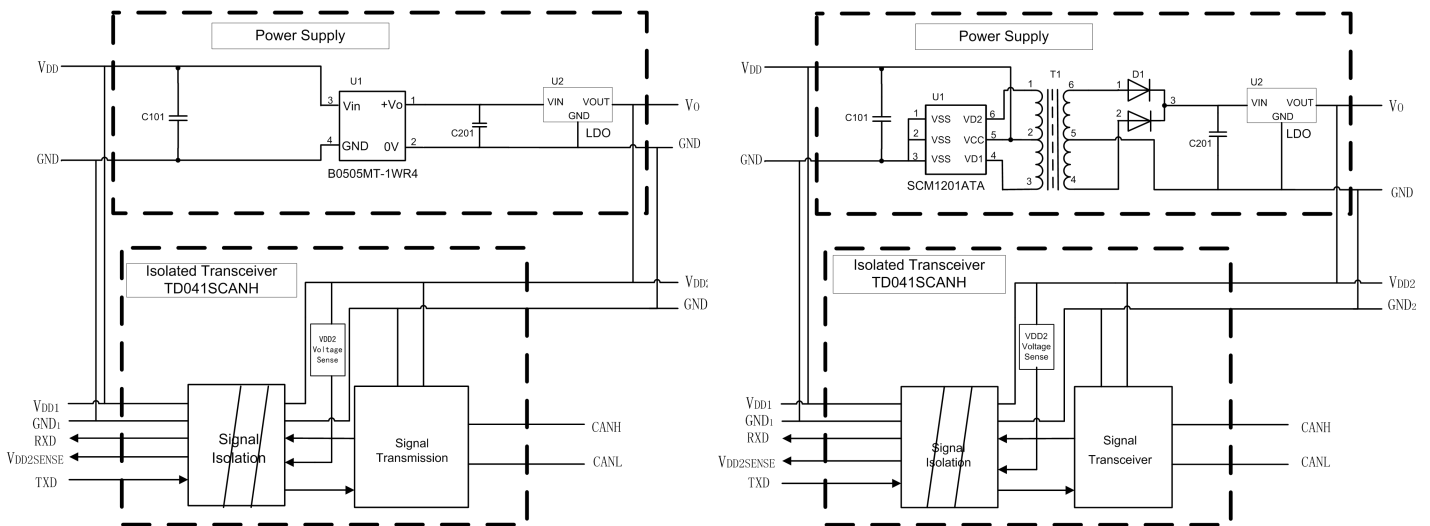

Figure 16. Drive and Receiver Propagation Drive

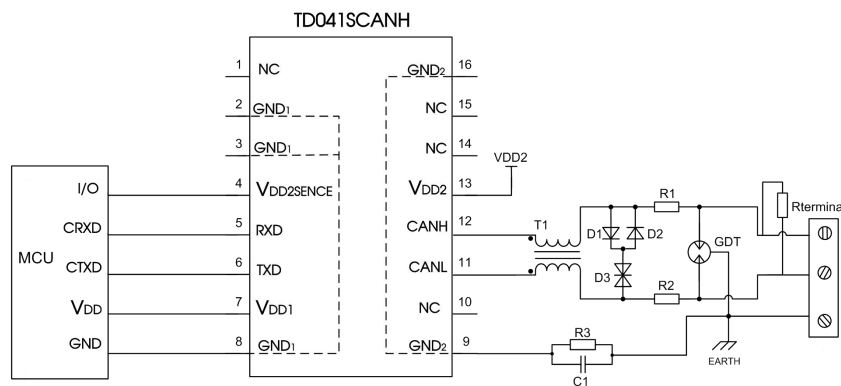

Figure 17. Port protection circuit for harsh environments

Recommended components and values:

Component	Recommended part, value	Component	Recommended part, value
R3	1M Ω	D1、D2	1N4007
C1	1nF, 2kV	D3	SMBJ30CA
T1	ACM2520-301-2P	R _{terminal}	120 Ω
GDT	B3D090L	R1、R2	2.7 Ω /2W

When the module is used in applications with harsh environment, it can be susceptible to large energy like lightning strike, etc. in which case, it is essential to add an adequate protection circuit to the CAN signal ports to protect the system from failure and maintain a reliable bus communication.

Figure 17 provides a recommended protection circuit design for high-energy lightning surges, with a degree of protection related to the selected protection device. Parameter description lists a set of recommended circuit parameters, which can be adjusted according to the actual application situation. Also, when using the shielded cable, the reliable single-point grounding of the shield must be achieved.

Note: The recommended components and values is a general guideline only and must be verified for the actual user's application. We recommended using PTC's for R1 and R2 and to use fast recovery diodes for D1 and D2.

Using Suggests

- ① Hot-swap is not supported.
- ② If the external input of TXD is insufficient, the pull-up resistor should be added according to the situation.
- ③ Refer to *IPC 7093* for the welding process design of this product. For detailed operation guidance, please refer to *Hot Air Gun Welding Operation Instruction for DFN Package Product* or *Welding Operation Instruction for DFN Package Product*.

Ordering Information

Part number	Package	Number of pins	Product Marking	Tape & Reel
TD041SCANH	DFN	16	TD041SCANH	500/REEL

Package Information(DFN-16)

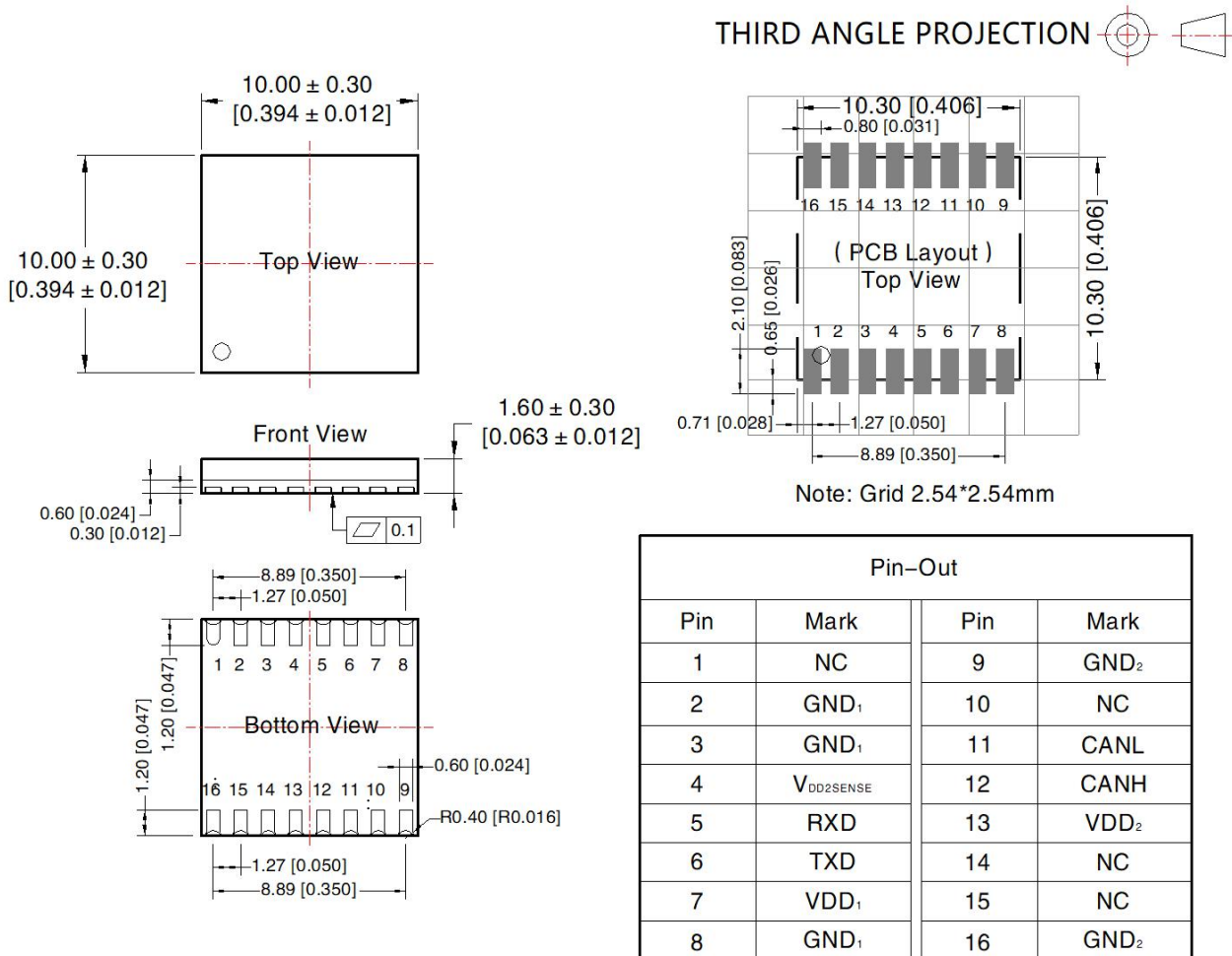

Note:
 Unit: mm[inch]
 General tolerances: ± 0.10 [± 0.004]

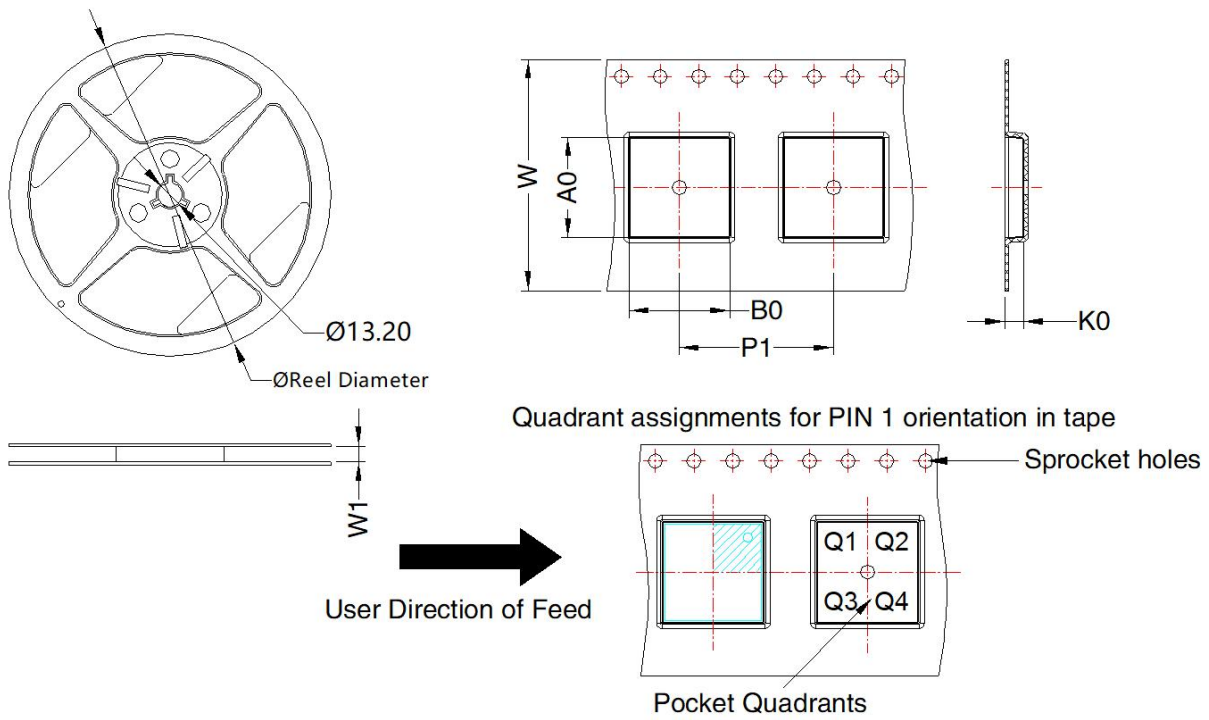

Device	Package Type	Pin	MPQ	Reel Diameter (mm)	Reel Width W1 (mm)	A0 (mm)	B0 (mm)	K0 (mm)	P1 (mm)	W (mm)	Pin1 Quadrant
TD041SCANH	DFN 10x10	16	500	180.0	24.4	10.44	10.44	2.0	16.0	24.0	Q2

MORNSUN Guangzhou Science & Technology Co., Ltd.

Address: No. 5, Kehui St. 1, Kehui Development Center, Science Ave., Guangzhou Science City, Huangpu District, Guangzhou, P. R. China
 Tel: 86-20-38601850 Fax: 86-20-38601272 E-mail: info@mornsun.cn www.mornsun-power.com